

PART LIST		
QTY	PART NUMBER	MASS
1	Type-II Headwall	1156.97 kg
2	5T x 65mm Lifting Inserts	0.04 kg

Notes:

- Type-II Headwall is built as shown.
- Unit supplied with energy dissipator blocks as shown.
- Unit supplied with rough core for inlet/outlet as shown.
- Suggested maximum core diameter: 400 mm.
- Structure supplied with embedded threaded inserts for grills and handrails.
- Bolt-on inlet/outlet grills and handrails are available upon request.
- Unit Supplied with Starcon style min. 5T/65mm lifting inserts to be used.
Note: Sling angle to the vertical no more than 20°.
- Minimum rebar yield strength: 400 MPa. (Steel Grade: CSA G30.18-400 Weldable)
- Minimum concrete strength : 30 MPa.
- All dimensions are in millimeters unless otherwise specified.

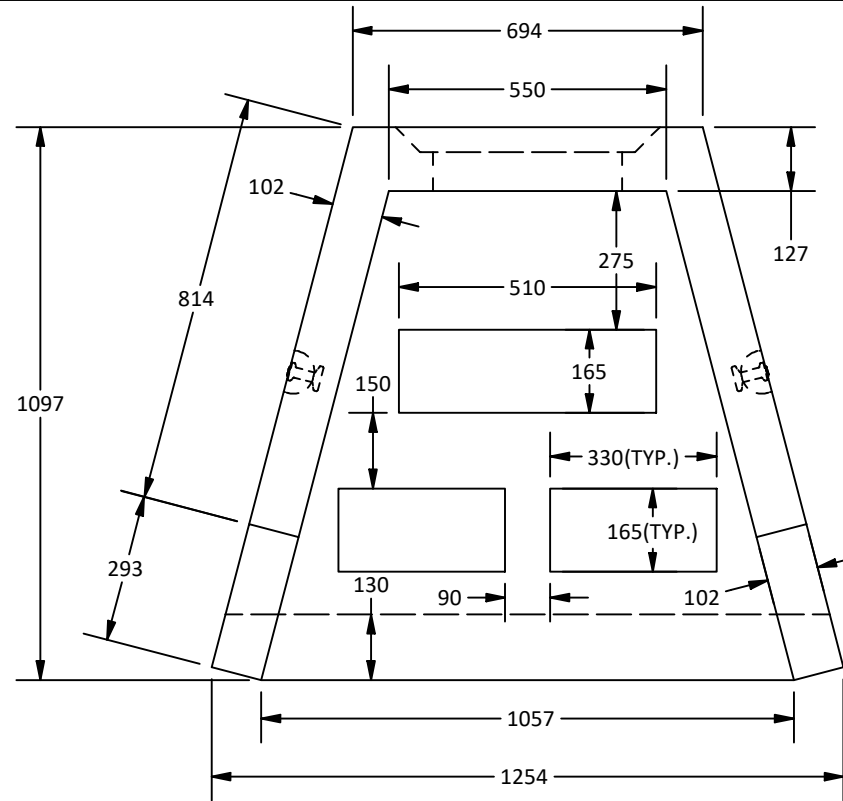

Plan View

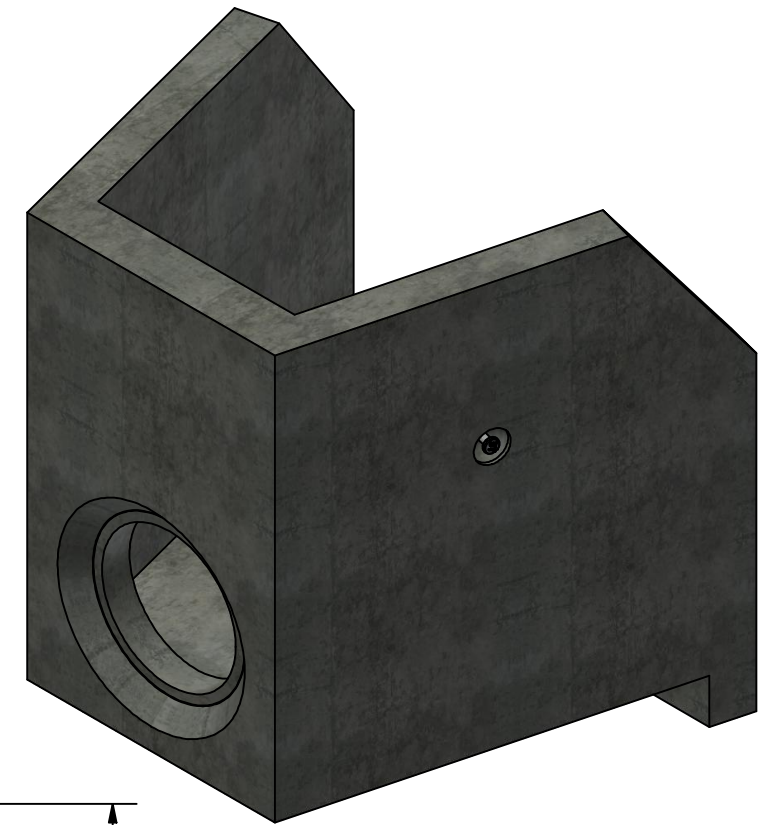

Isometric View

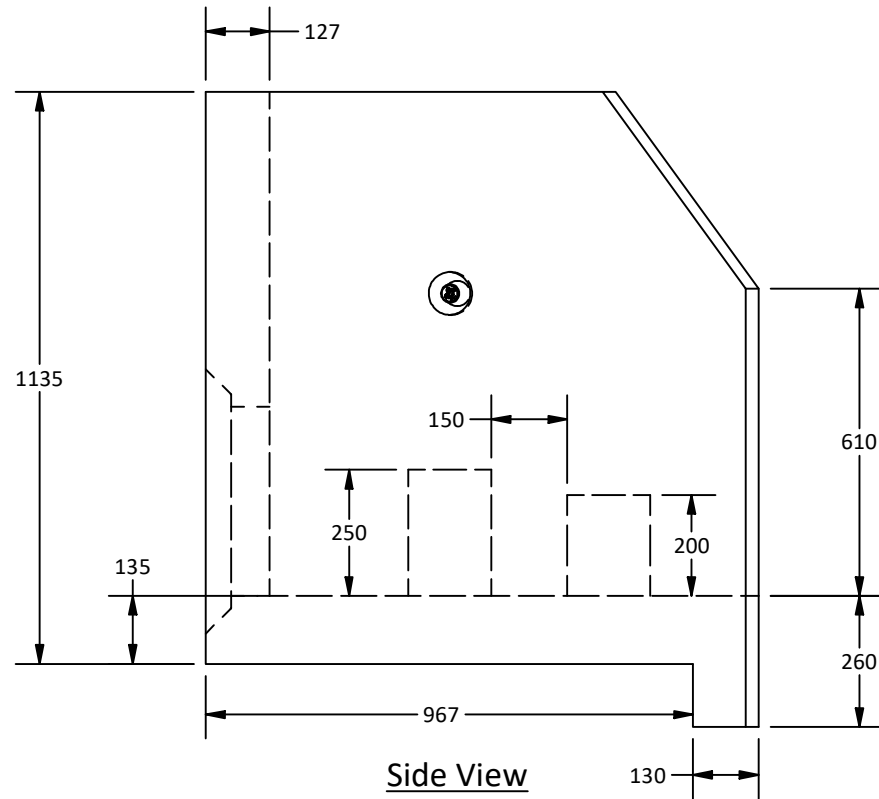

Side View

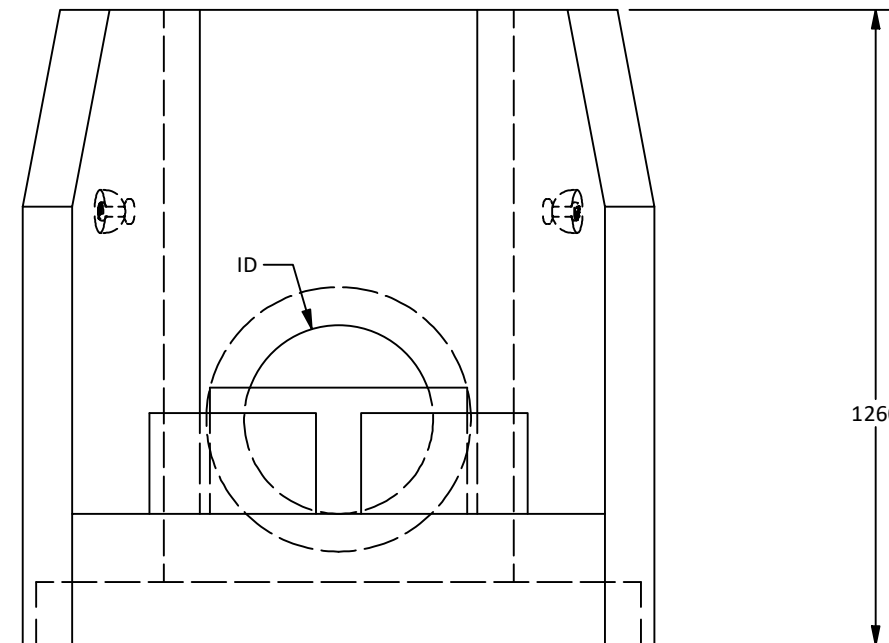

Elevation View

Amrize Canada Inc. BC Pipe and Precast are certified Q-Cast Plants, an American Concrete Pipe Association Third Party Certification for the manufacture of Pipe, Manhole, Box Culvert and Precast Items.



All Dimensions are in Millimeters. Unless otherwise Stated



www.amrize.com
CHILLIWACK 1-800 667-9600 / (604) 533-1656
DUNCAN (250) 478-9581

This drawing is the property of the Amrize Canada Inc. All information contained here in is confidential and may not be used in whole or in part without written permission from the owner.

DESCRIPTION:

Type-II Headwall
With Energy Dissipator Block

DRAWN BY: SR

DWG NO.: TYPE II HW - ED

CHK BY: MP

JOB NO.:

DATE: 21-Jul-25

SO NO.:

SCALE: 1:15

REV.:

SIZE: 11 x 17

SHEET 1 OF 1

Quality Assurance of products manufactured by Amrize Canada Inc. BC Pipe and Precast has been verified by the following third party certification programs.



Projection Method: THIRD ANGLE

