

PART LIST			
ITEM	QTY	PART NUMBER	MASS
1	1	Barrier	1100.868 kg
2	2	MK E2	0.407 kg

Note:

1. Precast concrete barrier manufactured to meet SP941-01.02.05 specifications.
2. Minimum rebar yield strength: 414 MPa. (Steel Grade: CSA G30.18-400 Weldable)
3. Minimum concrete strength: 35 MPa.
4. All reinforcing to have minimum 51 mm of concrete cover.
5. All tolerance ± 3 mm Except as note.
6. Hook and eye anchors each end shall be secured in place during casting to prevent sidlodgement.
7. Materials and quality of work to be in accordance with section 941.
8. Class of exposure: C-2.
9. All dimensions are in millimeters unless otherwise specified.

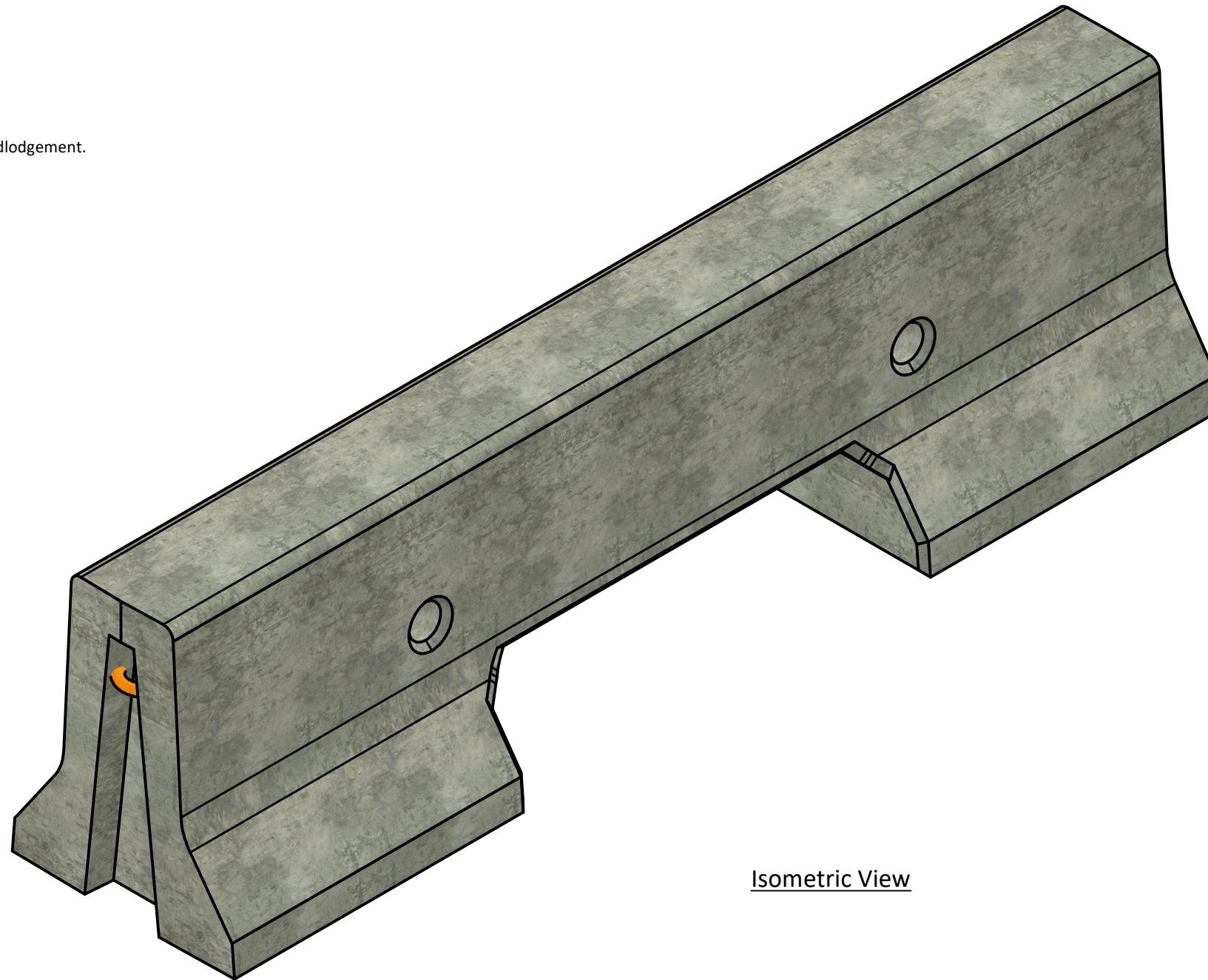

Isometric View

Amrize Canada Inc. BC Pipe and Precast are certified Q-Cast Plants, an American Concrete Pipe Association Third Party Certification for the manufacture of Pipe, Manhole, Box Culvert and Precast Items.



All Dimensions are in Millimeters. Unless otherwise Stated



www.amrize.com
CHILLIWACK 1-800 667-9600 / (604) 533-1656
DUNCAN (250) 478-9581

DESCRIPTION:

Precast Concrete Median Barrier
690 mm - CDB-E

DRAWN BY: SRA	DWG NO.: SP941-01.02.05
CHK BY: MP	JOB NO.: N/A
DATE: 13-Feb-25	SO NO.: N/A
SCALE: 1:10	REV.:
SIZE: 11 x 17	SHEET 1 OF 2

Quality Assurance of products manufactured by Amrize Canada Inc. BC Pipe and Precast has been verified by the following third party certification programs.



Projection Method:
THIRD ANGLE



This drawing is the property of the Amrize Canada Inc. All information contained here in is confidential and may not be used in whole or in part without written permission from the owner.

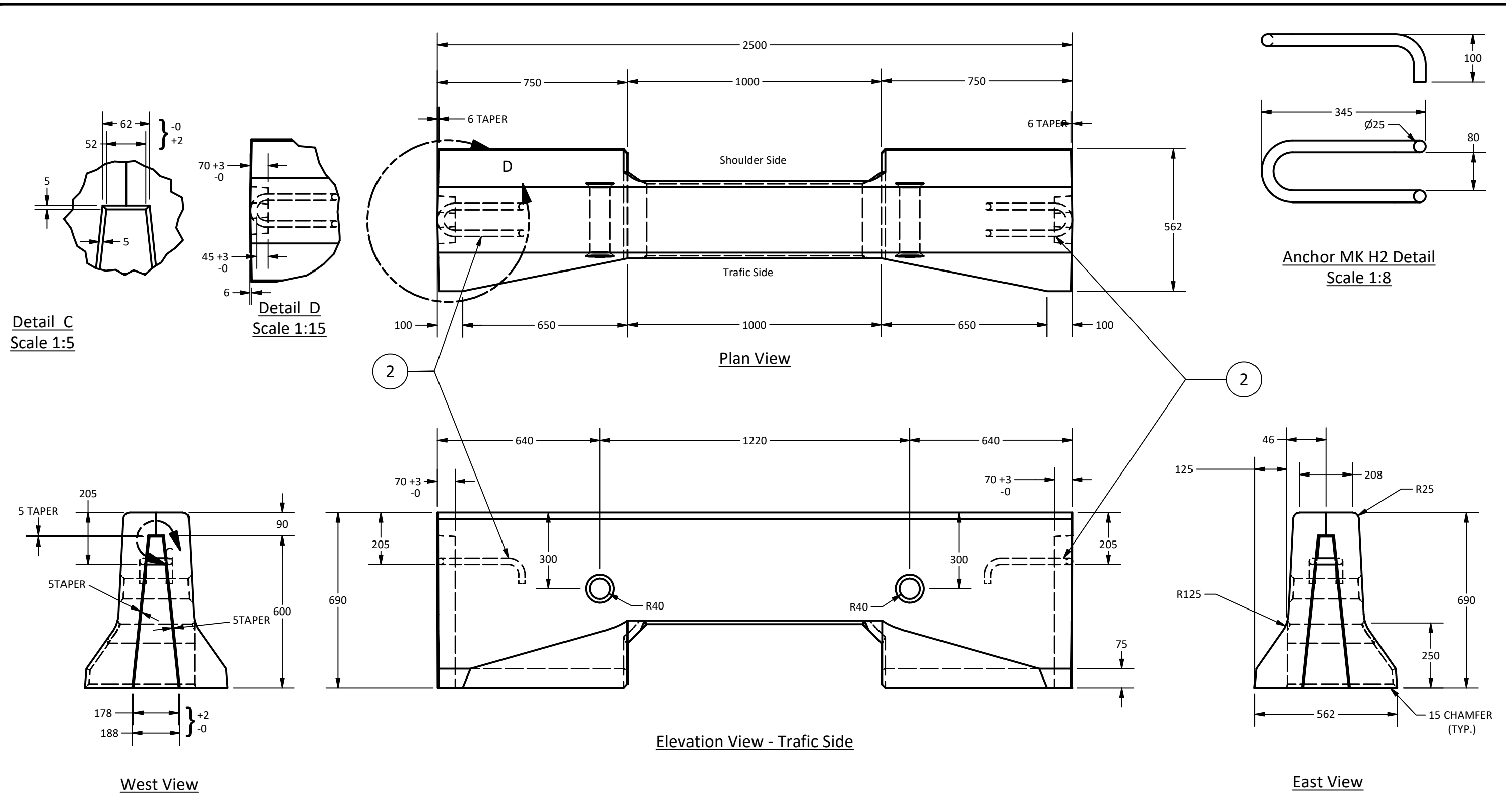

Amrize Canada Inc. BC Pipe and Precast are certified Q-Cast Plants, an American Concrete Pipe Association Third Party Certification for the manufacture of Pipe, Manhole, Box Culvert and Precast Items.



All Dimensions are in Millimeters. Unless otherwise Stated



www.amrize.com
CHILLIWACK 1-800 667-9600 / (604) 533-1656
DUNCAN (250) 478-9581

DESCRIPTION:

Precast Concrete Median Barrier
690 mm - CDB-E

DRAWN BY: SRA	DWG NO.: SP941-01.02.05
CHK BY: MP	JOB NO.: N/A
DATE: 13-Feb-25	SO NO.: N/A
SCALE: 1:15	REV.:
SIZE: 11 x 17	SHEET 2 OF 2

Quality Assurance of products manufactured by Amrize Canada Inc. BC Pipe and Precast has been verified by the following third party certification programs.



Projection Method:
THIRD ANGLE



This drawing is the property of the Amrize Canada Inc. All information contained here in is confidential and may not be used in whole or in part without written permission from the owner.