

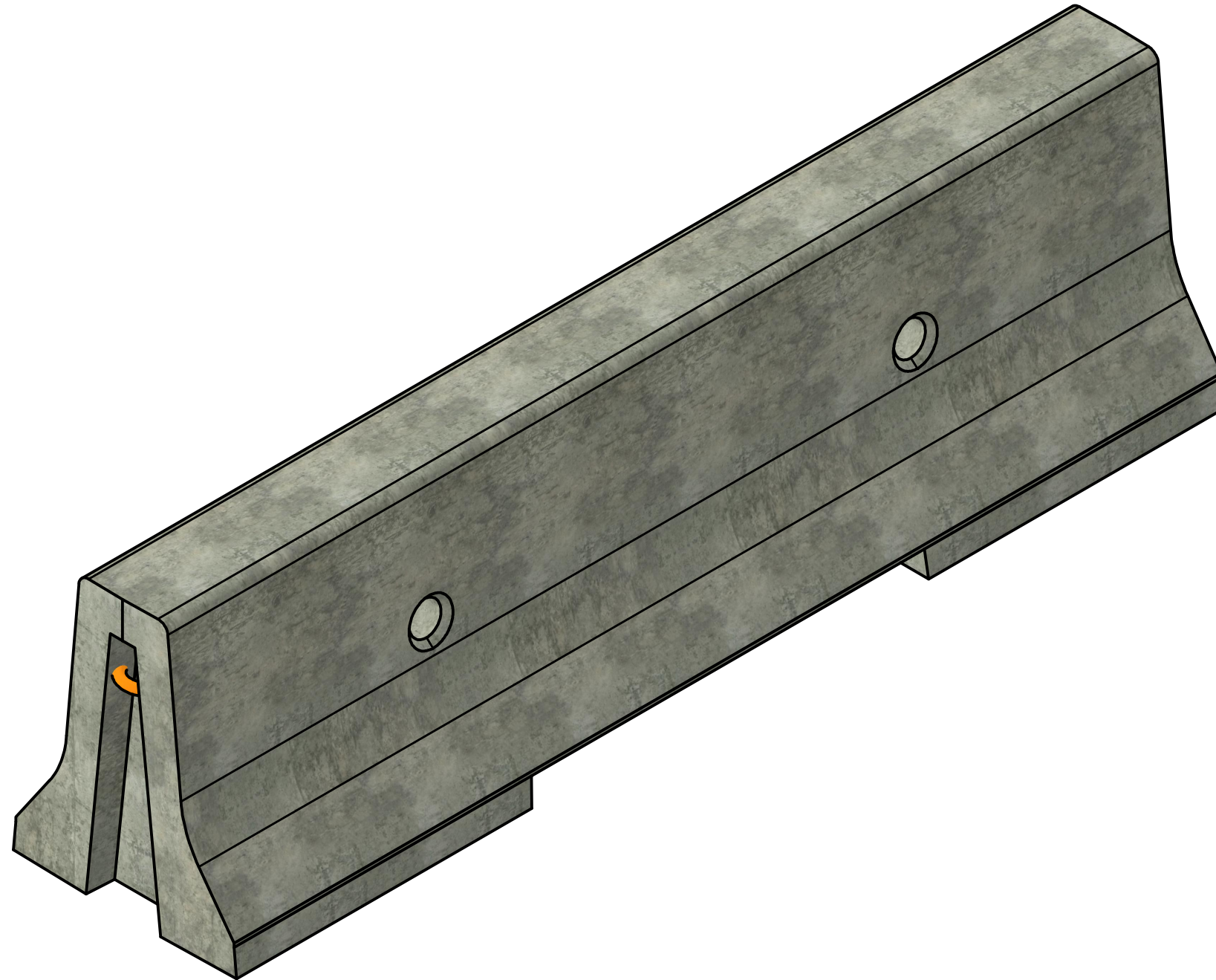





PART LIST			
ITEM	QTY	PART NUMBER	WEIGHT
1	1	Barrier	1,300 kg.
2	1	15M Rebar	
3	2	Anchor MK E2	

Note:

1. Precast concrete barrier manufactured to meet SP941-01.02.02 specifications.
2. Minimum rebar yield strength: 414 MPa. (Steel Grade: CSA G30.18-400 Weldable)
3. Minimum concrete strength: 32 MPa.
4. All reinforcing to have minimum 51 mm of concrete cover.
5. All tolerance ± 3 mm Except as noted.
6. Hook and eye anchors each end shall be secured in place during casting to prevent dislodgement.
7. Materials and quality of work to be in accordance with section 941.
8. Class of exposure: C-2.
9. Minimum Stripping Strength: 10MPa.
10. Unit can be supplied with drainage slot if required.
11. All dimensions are in millimeters unless otherwise specified.



Isometric View

Langley Concrete Group is a certified Q-Cast Plant, an American Concrete Pipe Association Third Party Certification for the manufacture of Pipe, Manhole, Box Culvert & Precast Items.		All Dimensions are in Millimeters. Unless otherwise Stated	 The LANGLEY CONCRETE Group of Companies www.langleyconcretegroup.com LANGLEY (604) 533-1656 DUNCAN (250) 478-9581 CHILLIWACK 1-800 667-9600	This drawing is the property of the Langley Concrete Group of Companies. All information contained herein is confidential and may not be used in whole or in part without written permission from the owner	DESCRIPTION: Precast Concrete Median Barrier 690 mm - CRB-E	DRAWN BY: SRA	DWG NO.: SP941-01.02.02
						CHK BY: MP	JOB NO.: N/A
Quality Assurance of products manufactured by The Langley Concrete Group has been verified by the following third party certification programs	 	Projection Method: THIRD ANGLE 				DATE: 13-Feb-25	SO NO.: N/A
						SCALE: 1:10	REV.:
						SIZE: 11 x 17	SHEET 1 OF 2

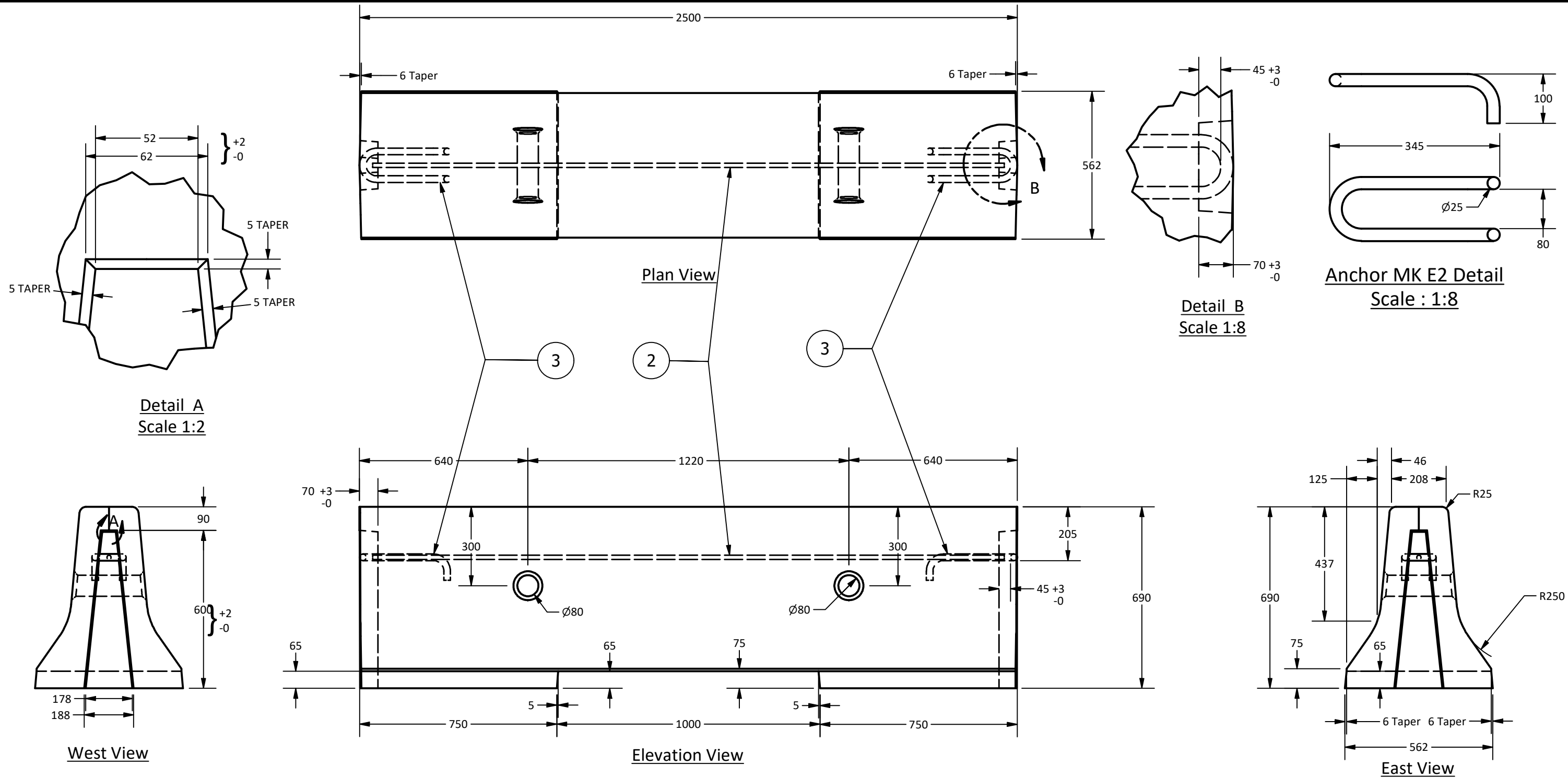

Langley Concrete Group is a certified Q-Cast Plant, an American Concrete Pipe Association Third Party Certification for the manufacture of Pipe, Manhole, Box Culvert & Precast Items.



All Dimensions are in Millimeters. Unless otherwise Stated



The **LANGLEY CONCRETE** Group of Companies
 www.langleyconcretegroup.com
 LANGLEY (604) 533-1656
 DUNCAN (250) 478-9581
 CHILLIWACK 1-800 667-9600

This drawing is the property of the Langley Concrete Group of Companies. All information contained herein is confidential and may not be used in whole or in part without written permission from the owner

DESCRIPTION:

Precast Concrete Median Barrier
 690 mm - CRB-E

DRAWN BY:	SRA	DWG NO.:	SP941-01.02.02
CHK BY:	MP	JOB NO.:	N/A
DATE:	13-Feb-25	SO NO.:	N/A
SCALE:	1:15	REV.:	
SIZE:	11 x 17	SHEET 2 OF 2	

Quality Assurance of products manufactured by The Langley Concrete Group has been verified by the following third party certification programs



Projection Method:
 THIRD ANGLE

