

PART LIST		
ITEM	PART NUMBER	WEIGHT
1	Ø1067mm Manhole Lid	550 kg.
2	Ø1067mm Manhole	1,100 kg/m.
3	Ø1067 Base	445 kg.
4	Ø1067mm Manhole Extended Base	560 kg.

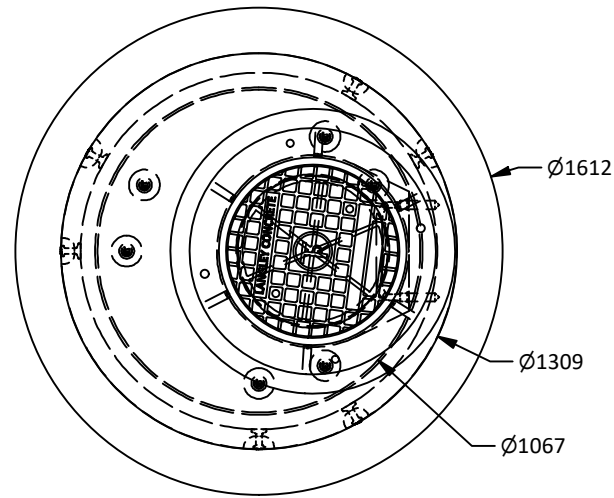

Plan View

Cast Iron Frame & Cover
to meet BCL625 / HS20 Loading

Grade Riser Rings
51, 76, 102mm Heights

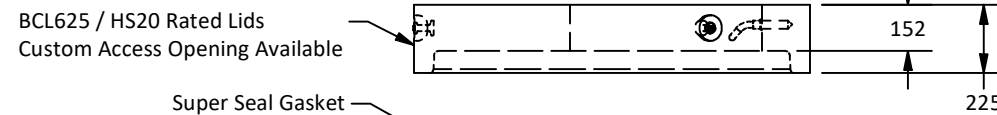

Standard Manhole Risers:
0.152m Height - Only for Ø1067mm Manhole
0.305m Height
0.610m Height
0.914m Height
1.219m Height

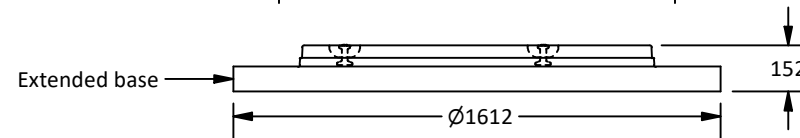
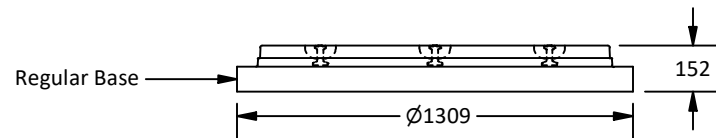
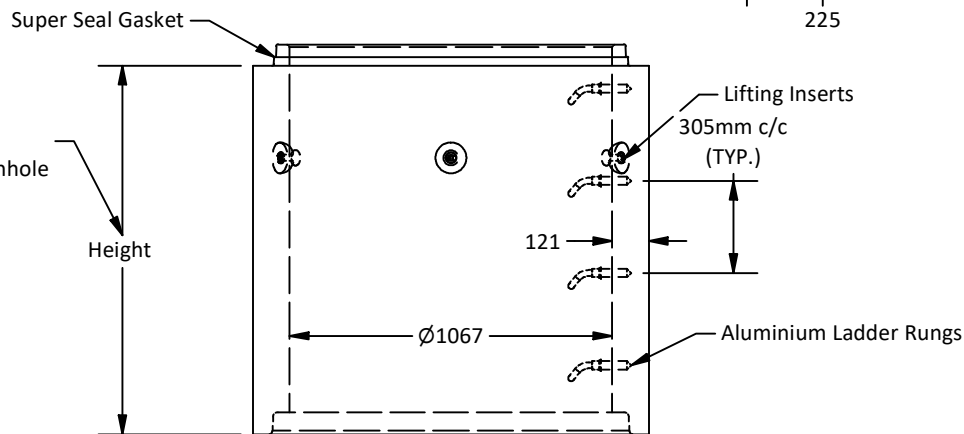

Elevation View



Isometric View

Note:

- Manhole manufactured to ASTM C478 and CSA 257.4 specifications.
- Concrete designed to withstand HS20 / BCL 625 live loadings.
- Unit supplied with Alum. ladder rungs as required.
- Unit supplied with lifting insert as required. Starcon style 5T x 65mm lifting inserts to be used.
Note: Sling angle to the vertical no more than 15°.
- WWF minimum yield strength: 485 MPa.
- Minimum rebar yield strength: 400 MPa. (Steel Grade: CSA G30.18-400 Weldable)
- Unit supplied with Tylox Super Seal Gasket System for water and soil/silt tight gasket and joint to meet or exceed ASTM C443, ASTM C1619 and CSA A-257.3.
- Minimum concrete strength:
Barrel: 30 MPa.
Lid & Base: 35 MPa.
- All reinforcing to have minimum 25.4 mm of concrete cover.
- All dimensions are in millimeters unless otherwise specified.

Amrize Canada Inc. BC Pipe and Precast are certified Q-Cast Plants, an American Concrete Pipe Association Third Party Certification for the manufacture of Pipe, Manhole, Box Culvert and Precast Items.



All Dimensions are in Millimeters. Unless otherwise Stated



www.amrize.com
CHILLIWACK 1-800 667-9600 / (604) 533-1656
DUNCAN (250) 478-9581

DESCRIPTION:

Ø1067mm Manhole
Designed for BCL625 / HS20 Loading and
5.0m Maximum Bury Depth

Quality Assurance of products manufactured by Amrize Canada Inc. BC Pipe and Precast has been verified by the following third party certification programs.



Projection Method:
THIRD ANGLE



This drawing is the property of the Amrize Canada Inc. All information contained here in is confidential and may not be used in whole or in part without written permission from the owner.

DRAWN BY:
SR

DWG NO.:

CHK BY:
MP

JOB NO.:
MH-1050

DATE:
11-Jul-25

SO NO.:

SCALE:
1:25

REV.:

SIZE:
11 x 17

SHEET 1 OF 1