

PART LIST			
ITEM	QTY	PART NUMBER	WEIGHT
1	1	2100mm Pole Base	1,840 kg.
2	2	5 x 110 Lifting Insert	

OPTION'S	
BOLT SPACING (mm)	GALVANIZED ANCHOR BOLT
150	19 x 610mm
160	19 x 610 mm
180	25 x 920 mm
197	25 x 920 mm

- Notes:
1. 2100mm Precast Parking Lot Pole Base to be built as shown.
 2. Unit supplied with required anchor bolts, spacing PVC conduits as required.
 3. Unit c/w lifting inserts as required.
 4. Unit Supplied with Nuts and Washers as required.
 5. Minimum concrete strength: 30 MPa.
 6. All dimensions are in millimeters.
 7. Installation & backfilling is the responsibility of others.
 10. V- Groove Drain Trough to Start at Zero Depth in Centre of Base to 10mm at the Outside edge. Align with Conduit.

Note: 25mm Spacing between Conduits

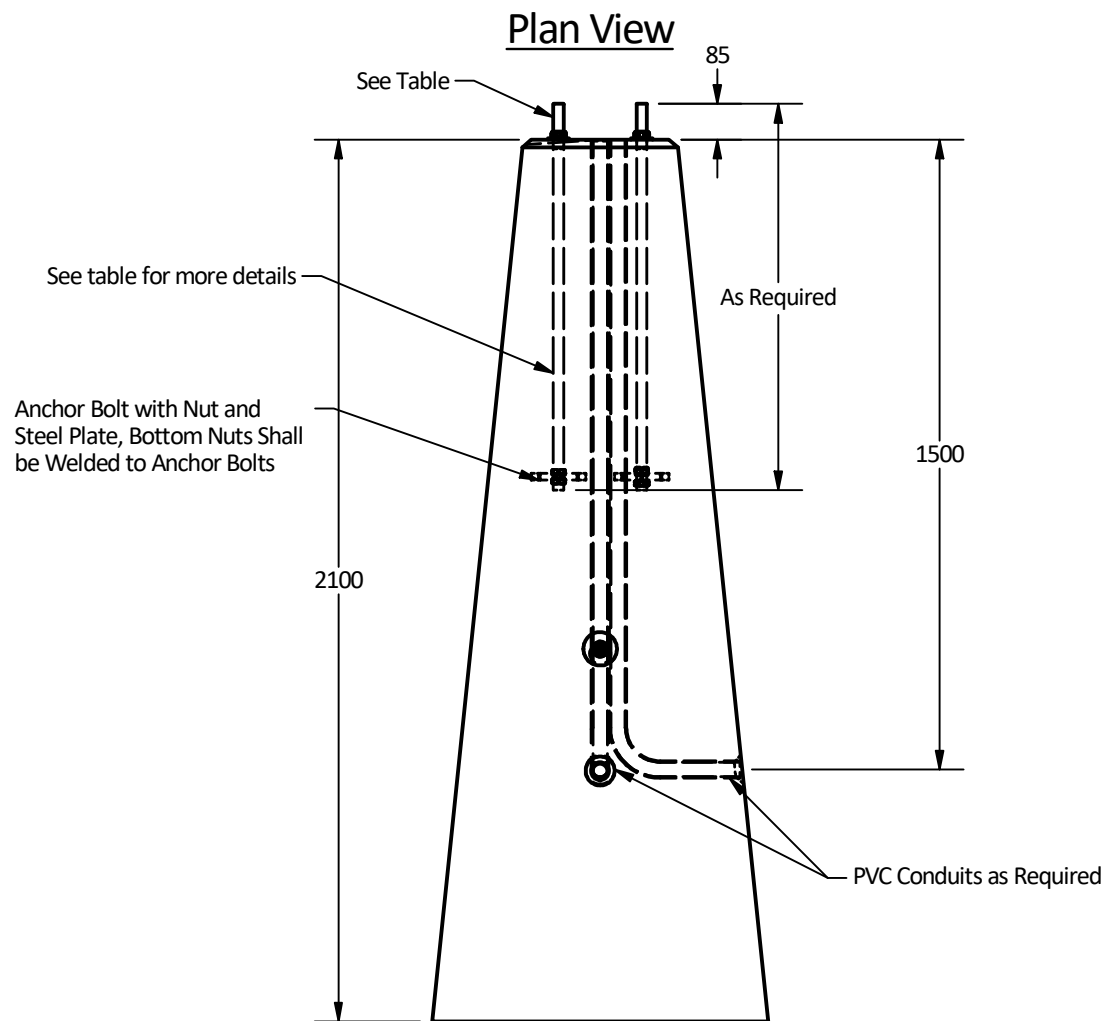
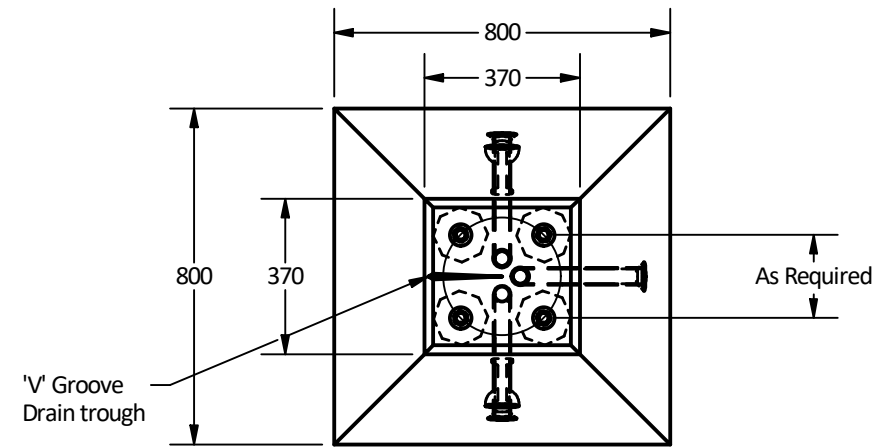

Elevation View

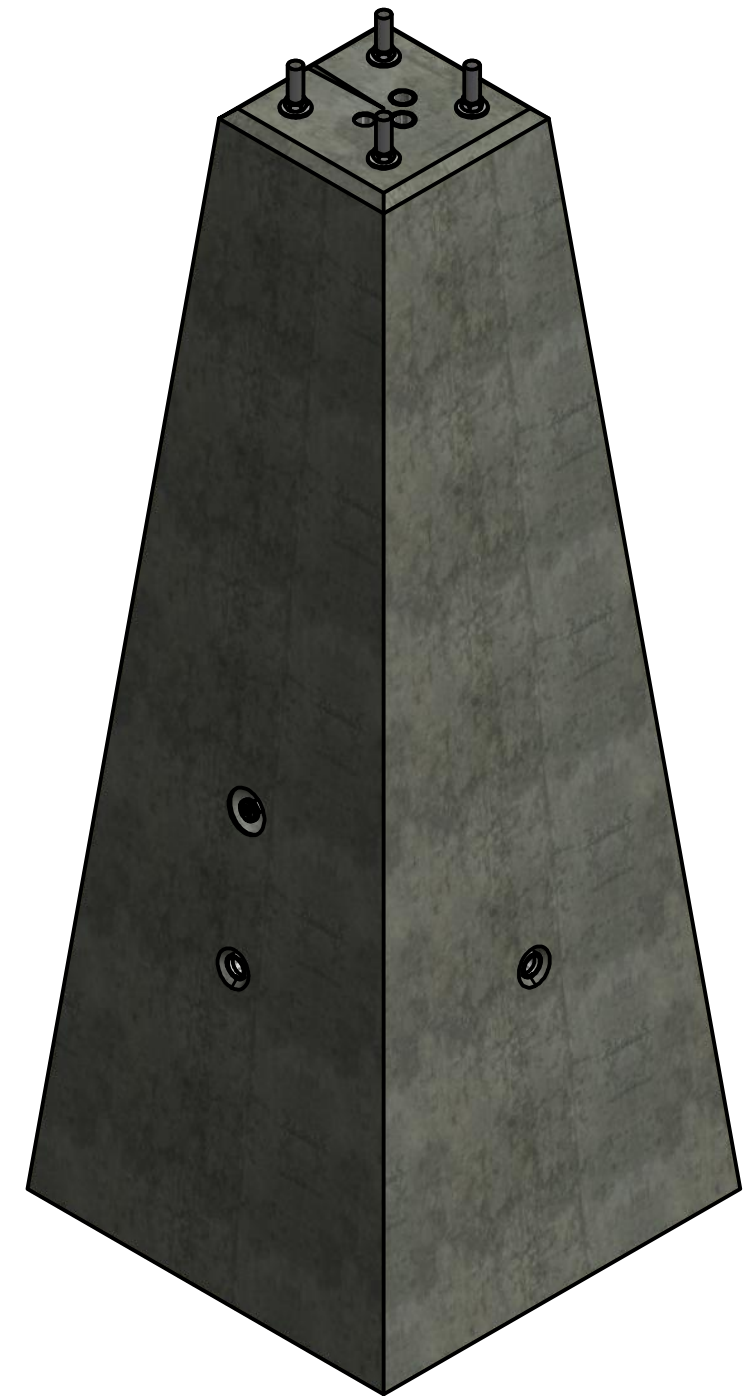

Isometric View

Langley Concrete Group is a certified Q-Cast Plant, an American Concrete Pipe Association Third Party Certification for the manufacture of Pipe, Manhole, Box Culvert & Precast Items.



Quality Assurance of products manufactured by The Langley Concrete Group has been verified by the following third party certification programs



All Dimensions are in Millimeters. Unless otherwise Stated

Projection Method: THIRD ANGLE



The **LANGLEY CONCRETE** Group of Companies
 www.langleyconcretegroup.com
 LANGLEY (604) 533-1656
 VICTORIA (250) 478-9581
 CHILLIWACK 1-800 667-9600

This drawing is the property of the Langley Concrete Group of Companies. All information contained herein is confidential and may not be used in whole or in part without written permission from the owner

DESCRIPTION:

Precast Concrete Pole Base
 2100 mm Parking Lot Pole
 NON-MMCD

DRAWN BY:	BY	JOB NO.
CHK BY:	KS	DWG NO: LPB-2100-NON-MMCD
DATE:	Jan.03, 2020	LC NO:
SCALE:	1:18	MU NO:
SIZE	11 x 17	REV.
		SHEET 1 OF 1