

Span x Height (m)	Width (m)	Max. Height (m)	Thickness (m)	Weight (kg)
2.1-3.7	2.1	3.7	0.254	15,465
2.6-3.7	2.6	3.7	0.254	17,185
3.1-3.7	3.1	3.7	0.254	18,910
3.6-3.7	3.6	3.7	0.254	20,635
4.1-3.7	4.1	3.7	0.254	22,365
4.6-3.7	4.6	3.7	0.254	24,085
5.1-3.7	5.1	3.7	0.254	25,815
5.6-3.7	5.6	3.7	0.254	29,700
6.1-3.7	6.1	3.7	0.254	31,500

Notes:

- 'Headwall Max' adjustable large headwall to be built as shown.
- Backwall height can be manufactured to varying heights as required to suit jobsite conditions. (Maximum 3.7m)
- Unit will be supplied with opening as required.
- Structure supplied with embedded threaded inserts for handrails.
- Inlet and outlet grilles to be mounted onsite, precast concrete headwalls supplied without inserts, inserts to be drilled onsite by others.
- Unit supplied with lifting inserts as required.
- Minimum rebar yield strength: 400 MPa.(Steel Grade: CSA G30.18-400 Weldable)
- Minimum concrete strength: 35 MPa.
- All dimensions are in millimeters unless otherwise specified.

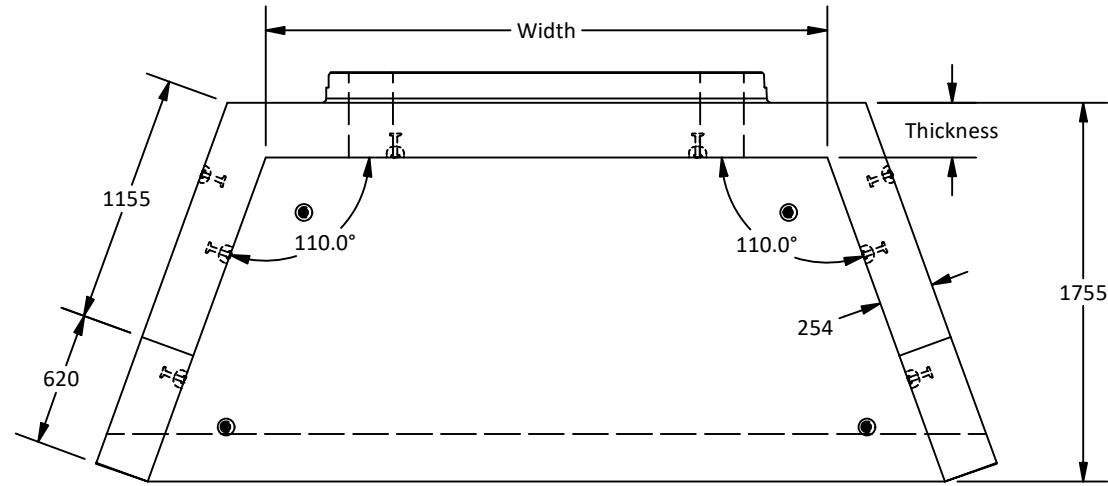

Plan View

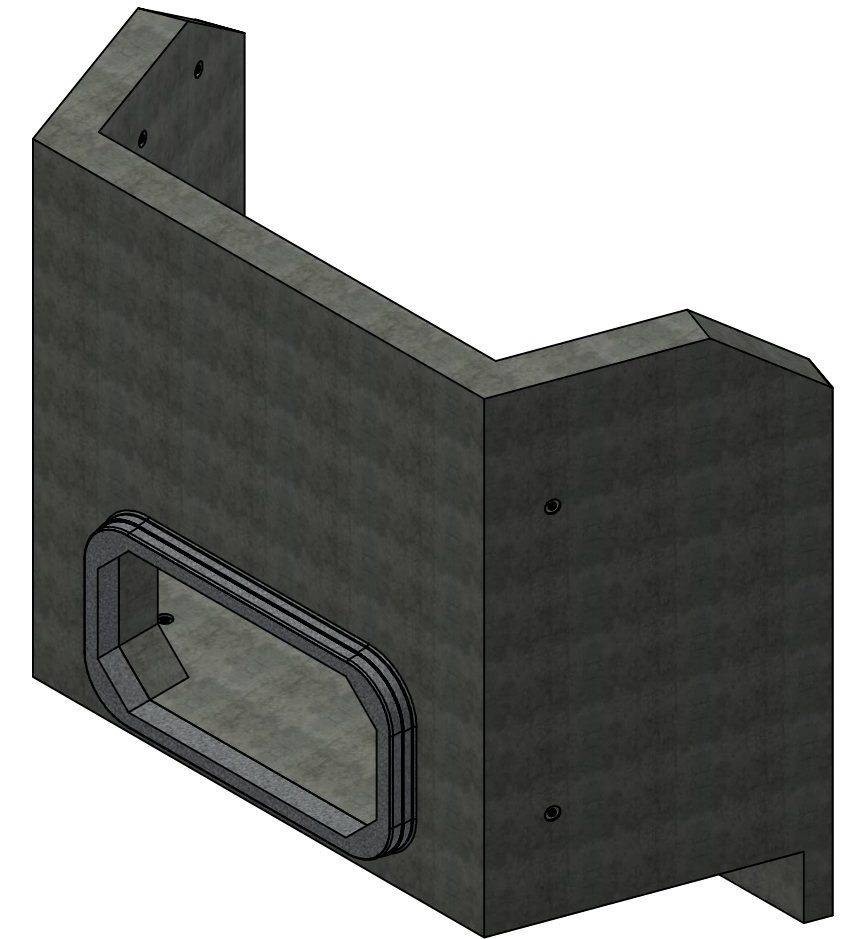

Isometric View

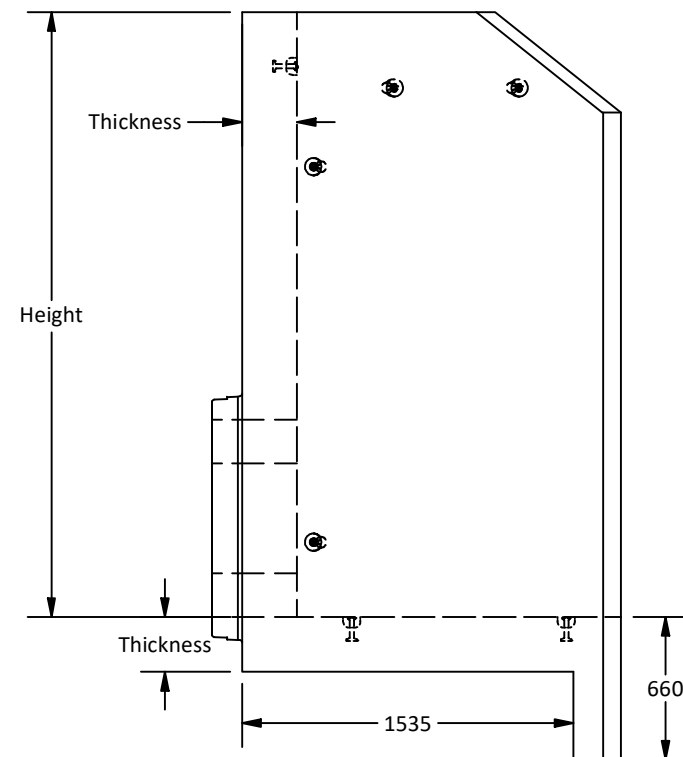

Section View

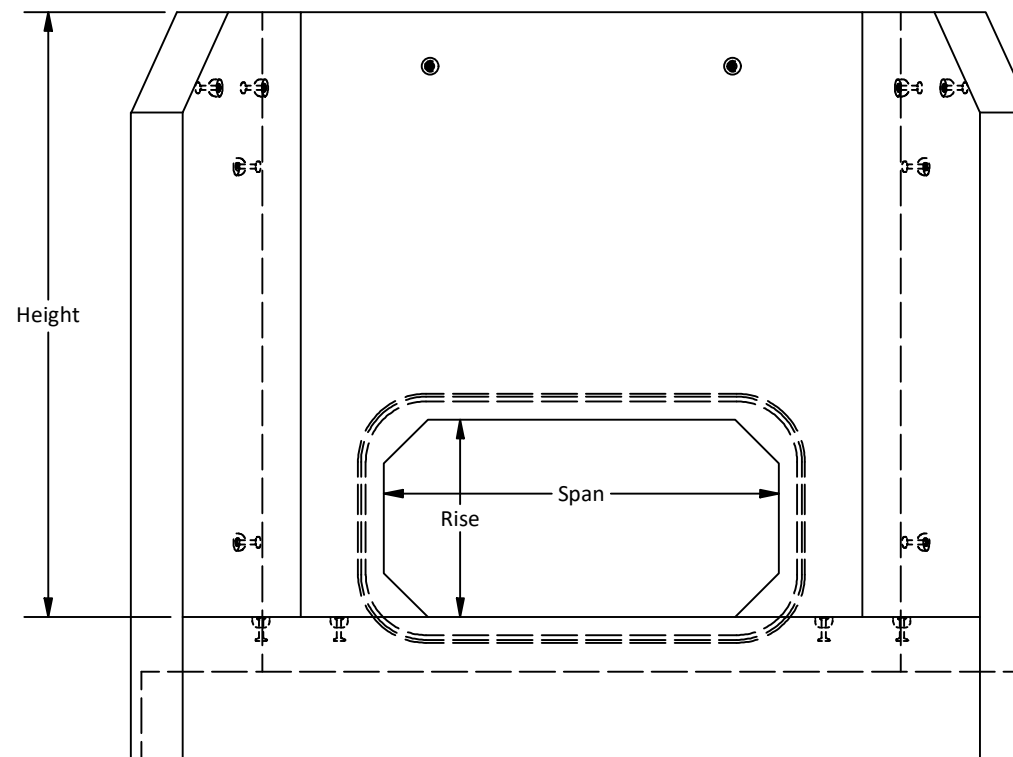

Elevation View

Amrize Canada Inc. BC Pipe and Precast are certified Q-Cast Plants, an American Concrete Pipe Association Third Party Certification for the manufacture of Pipe, Manhole, Box Culvert and Precast Items.



All Dimensions are in Millimeters. Unless otherwise Stated



www.amrize.com
CHILLIWACK 1-800 667-9600 / (604) 533-1656
DUNCAN (250) 478-9581

DESCRIPTION:

Inlet Headwall Max Series
with Opening for Box Culvert

DRAWN BY: SR

DWG NO.: HW-Max-BCO-Inlet

CHK BY: MP

JOB NO.:

DATE: 25-Jul-25

SO NO.: N/A

SCALE: 1:35

REV.:

SIZE: 11 x 17

SHEET 1 OF 1

Quality Assurance of products manufactured by Amrize Canada Inc. BC Pipe and Precast has been verified by the following third party certification programs.



Projection Method: THIRD ANGLE



This drawing is the property of the Amrize Canada Inc. All information contained here in is confidential and may not be used in whole or in part without written permission from the owner.