

Notes:

- * Maximum Surface Loading Rate (SLR) into lower chamber through drop pipe is 1135 L/min/m² (27.9 gpm/ft²) for Stormceptor EF8 and 535 L/min/m² (13.1 gpm/ft²) for Stormceptor EFO8 (oil capture configuration).
- 1. Ø2438 mm Manhole manufactured to ASTM C 478 and CSA A257.4 Specifications.
- 2. Stormceptor EFO8 to be supplied in components as shown.
- 3. Unit designed to withstand BCL 625 / HS20 live loading.
- 4. Unit supplied with cores for inlet/outlet as shown.
- 5. Unit supplied with ladder rungs as shown
- 6. Unit supplied with lifting inserts as required. Starcon style min. 10T/180mm lifting inserts to be used.
 - Note: Sling angle to the vertical no more than 15°.
- 7. Unit supplied with access opening as required.
- 8. Minimum concrete strength:
 - Barrel: 30 MPa.
 - Lid & Base: 35 MPa.
- 9. Minimum rebar yield strength: 485 MPa. (Steel Grade: CSA 30.18-400 Weldable)
- 10. Minimum WWF yield strength: 400 MPa. (Steel Grade: ASTM A1064)
- 11. All reinforcing to have minimum 25.4 mm of concrete cover.
- 12. Barrel configuration subject to change based on availability.
- 13. Unit supplied with Tylox Super Seal Gasket System for water and soil/silt tight gasket and joint to meet or exceed ASTM C443, ASTM C1619 and CSA A-257.3.
- 14. All dimensions are in millimeters unless otherwise specified.

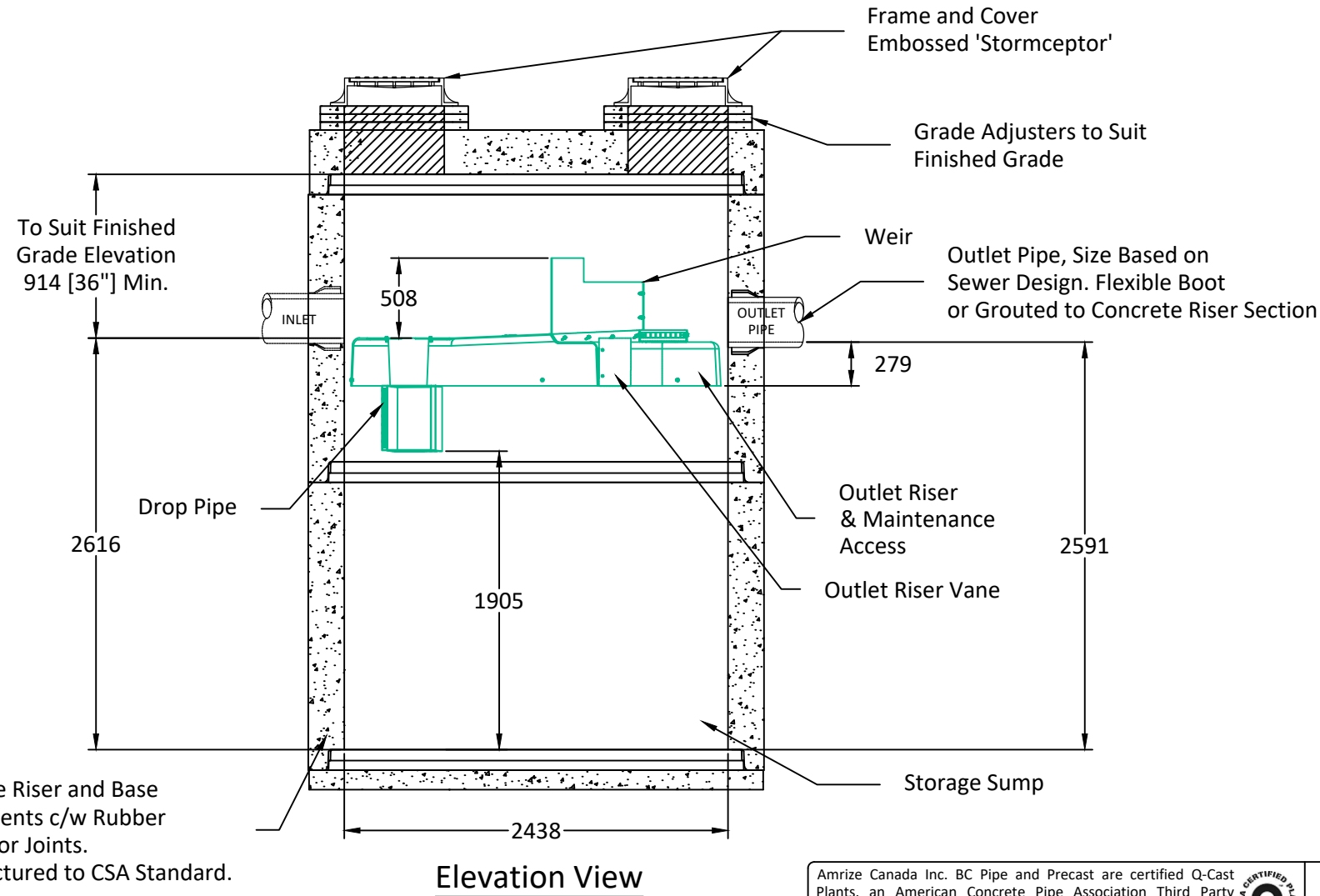

Concrete Riser and Base Components c/w Rubber Gasket for Joints.
Manufactured to CSA Standard.

Amrize Canada Inc. BC Pipe and Precast are certified Q-Cast Plants, an American Concrete Pipe Association Third Party Certification for the manufacture of Pipe, Manhole, Box Culvert and Precast Items.

Quality Assurance of products manufactured by Amrize Canada Inc. BC Pipe and Precast has been verified by the following third party certification programs.

All Dimensions are in Millimeters. Unless otherwise Stated

Projection Method: THIRD ANGLE



www.amrize.com

DESCRIPTION:

EFO8
Standard Drawing

DRAWN BY: JC	DWG NO: EFO8
CHK BY: MP	SO NO.:
DATE: Oct.17, 2025	REV.
SCALE: 1:##	SIZE.

This drawing is the property of Amrize Canada Inc. All information contained here in is confidential and may not be used in whole or in part without written permission from the owner.

CHILLIWACK 1-800 667-9600 / (604)533-1656

DUNCAN (250) 478-9581