

Plan View

Optional Inlet Pipe
(or Multiple Inlet Pipes)
25 mm [1"] Difference
Between Inlet Invert
and Outlet Invert

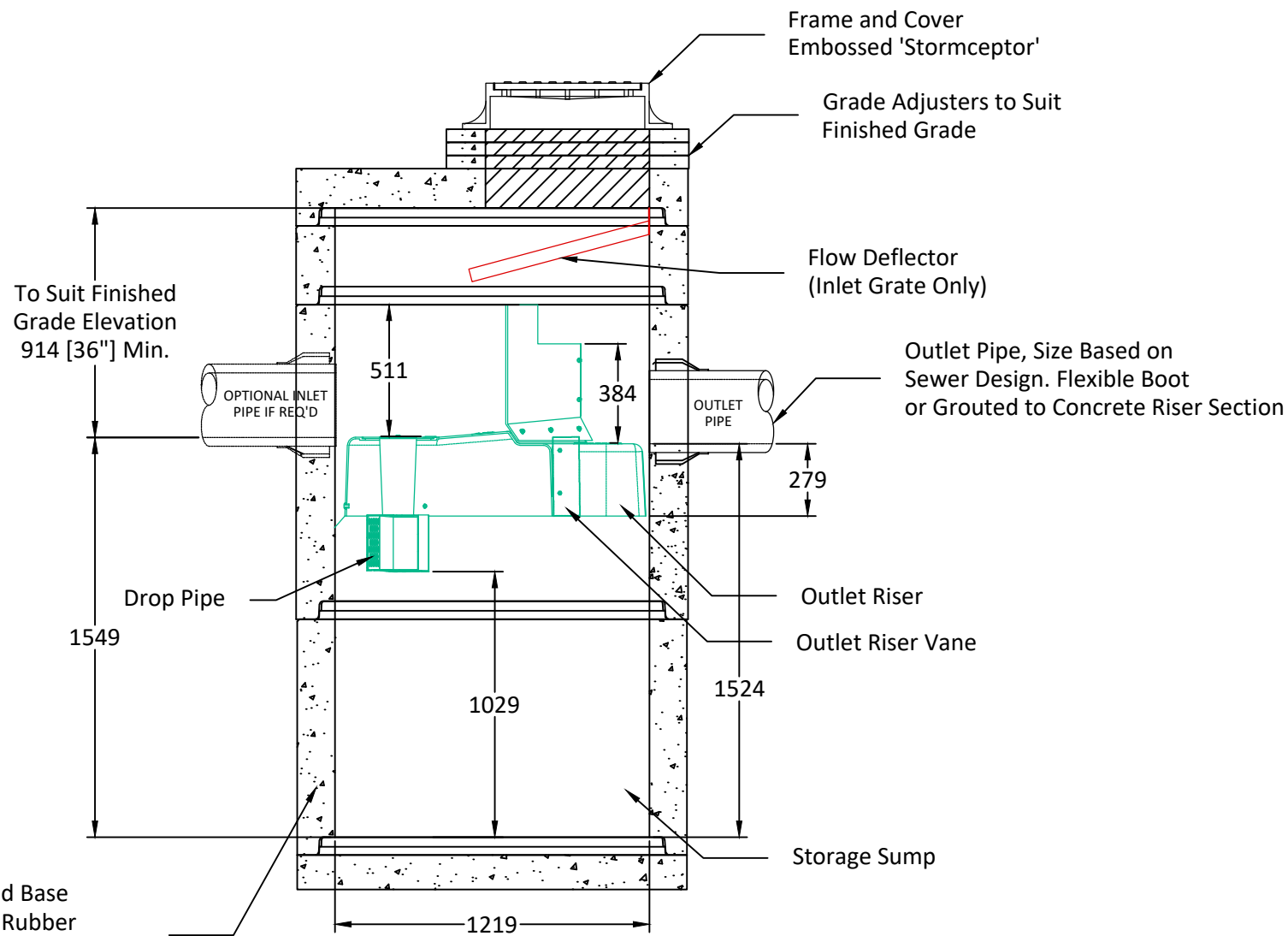

Elevation View

Concrete Riser and Base
Components c/w Rubber
Gasket for Joints.
Manufactured to CSA Standard.

Notes:

- * Maximum Surface Loading Rate (SLR) into lower chamber through drop pipe is 1135 L/min/m² (27.9 gpm/ft²) for Stormceptor EF4 and 535 L/min/m² (13.1 gpm/ft²) for Stormceptor EFO4 (oil capture configuration). Weir height is 150 mm (6 inch) for EF04.
- 1. Ø1219 mm Manhole manufactured to ASTM C 478 & CSA A257.4 Specifications.
- 2. Stormceptor EF4 to be supplied in components as shown.
- 3. Unit designed to withstand BCL-625 / HS20 live loading.
- 4. Unit supplied with cores for inlet/outlet as shown.
- 5. Unit supplied with lifting inserts as required. Starcon style min. 5T/65mm lifting inserts to be used.
 - Note: Sling angle to the vertical no more than 15°.
- 6. Unit supplied with access opening as required.
- 7. Minimum concrete strength:
 - Barrel: 30 MPa.
 - Lid & Base: 35 MPa.
- 8. Unit supplied with Tylox Super Seal Gasket System for water and soil/silt tight gasket and joint to meet or exceed ASTM C443, ASTM C1619 and CSA A257.3.
- 9. Minimum rebar yield strength: 485 MPa. (Steel Grade: CSA 30.18-400 Weldable)
- 10. Minimum WWF yield strength: 400 MPa. (Steel Grade: ASTM A1064)
- 11. Barrels configuration's subject to change based on availability.
- 12. All dimensions are in millimeters unless otherwise specified.

Amrize Canada Inc. BC Pipe and Precast are certified Q-Cast Plants, an American Concrete Pipe Association Third Party Certification for the manufacture of Pipe, Manhole, Box Culvert and Precast Items.

Quality Assurance of products manufactured by Amrize Canada Inc. BC Pipe and Precast has been verified by the following third party certification programs.

All Dimensions are in Millimeters. Unless otherwise Stated

Projection Method: THIRD ANGLE



www.amrize.com

DESCRIPTION:

EF4
Standard Drawing

DRAWN BY: JC	DWG NO: EF4
CHK BY: MP	SO NO.:
DATE: Oct.17, 2025	REV.
SCALE: 1:##	SIZE.

This drawing is the property of Amrize Canada Inc. All information contained here in is confidential and may not be used in whole or in part without written permission from the owner.

CHILLIWACK 1-800 667-9600 / (604)533-1656

DUNCAN (250) 478-9581