

### Box Culvert Information

Span x Rise Nominal (mm)	Span x Rise Actual (mm)	Weights per linear Meter in kg	Wall Thickness in (mm)	Box Manhole Lid Weight in kg	Box Manhole Base Weight in kg
1800 x 900	1829 x 914	3,400	203.2	1,800	1,300
1800 x 1200	1829 x 1219	3,700	203.2	2,200	1,600
1800 x 1500	1829 x 1524	4,000	203.2	2,500	1,900
1800 x 1800	1829 x 1829	4,400	203.2	2,900	2,300
2100 x 900	2134 x 914	3,600	203.2	1,800	1,600
2100 x 1200	2134 x 1219	4,000	203.2	2,400	1,800
2100 x 1500	2134 x 1524	4,400	203.2	2,800	2,200
2100 x 1800	2134 x 1829	4,700	203.2	3,200	2,600
2100 x 2100	2134 x 2134	5,000	203.2	3,700	2,900
2400 x 900	2438 x 914	4,000	203.2	2,000	1,800
2400 x 1200	2438 x 1219	4,400	203.2	2,700	2,100
2400 x 1500	2438 x 1524	4,700	203.2	3,200	2,500
2400 x 1800	2438 x 1829	5,000	203.2	3,600	2,900
2400 x 2100	2438 x 2134	5,300	203.2	4,100	3,300
2400 x 2400	2438 x 2438	5,600	203.2	4,500	3,700
2700 x 900	2743 x 914	4,800	228.6	2,500	2,200
2700 x 1200	2743 x 1219	5,300	228.6	3,400	2,700
2700 x 1500	2743 x 1524	5,700	228.6	4,000	3,300
2700 x 1800	2743 x 1829	6,000	228.6	4,600	3,800
2700 x 2100	2743 x 2134	6,400	228.6	5,200	4,300
2700 x 2400	2743 x 2438	6,700	228.6	5,700	4,900
2700 x 2700	2743 x 2743	7,000	228.6	6,300	5,400
3050 x 900	3048 x 914	5,800	254	2,900	2,500
3050 x 1200	3048 x 1219	6,400	254	4,300	3,500
3050 x 1500	3048 x 1524	6,800	254	5,000	4,200
3050 x 1800	3048 x 1829	7,200	254	5,700	4,900
3050 x 2100	3048 x 2134	7,500	254	6,400	5,500
3050 x 2400	3048 x 2438	7,900	254	7,100	6,200
3050 x 2700	3048 x 2743	8,300	254	7,800	6,900
3050 x 3050	3048 x 3048	8,700	254	8,500	7,500

Span x Rise Nominal (mm)	Span x Rise Actual (mm)	Weights per linear Meter in kg	Wall Thickness in (mm)	Box Manhole Lid Weight in kg	Box Manhole Base Weight in kg
3350 x 900	3353 x 914	7,000	279.4	3,400	2,900
3350 x 1200	3353 x 1219	7,500	279.4	5,300	4,500
3350 x 1500	3353 x 1524	8,000	279.4	6,100	5,300
3350 x 1800	3353 x 1829	8,400	279.4	7,000	6,100
3350 x 2100	3353 x 2134	8,800	279.4	7,800	6,900
3350 x 2400	3353 x 2438	9,200	279.4	8,700	7,700
3350 x 2700	3353 x 2743	9,700	279.4	9,500	8,500
3350 x 3050	3353 x 3048	10,100	279.4	10,400	9,300
3350 x 3350	3353 x 3353	10,500	279.4	11,200	10,100
3650 x 900	3658 x 914	8,200	304.8	3,900	3,200
3650 x 1200	3658 x 1219	8,800	304.8	6,400	5,500
3650 x 1500	3658 x 1524	9,300	304.8	7,400	6,500
3650 x 1800	3658 x 1829	9,700	304.8	8,400	7,400
3650 x 2100	3658 x 2134	10,200	304.8	9,400	8,400
3650 x 2400	3658 x 2438	10,600	304.8	10,400	9,400
3650 x 2700	3658 x 2743	11,100	304.8	11,400	10,300
3650 x 3050	3658 x 3048	11,600	304.8	12,400	11,300
3650 x 3350	3658 x 3353	12,000	304.8	13,400	12,300
3650 x 3650	3658 x 3658	12,500	304.8	14,400	13,200
4250 x 900	4267 x 914 **	9,100	304.8	4,500	3,700
4250 x 1200	4267 x 1219 **	9,700	304.8	7,300	6,300
4250 x 1500	4267 x 1524 **	10,200	304.8	8,400	7,400
4250 x 1800	4267 x 1829 **	10,500	304.8	9,600	8,500
4250 x 2100	4267 x 2134 **	11,100	304.8	10,700	9,600
4250 x 2400	4267 x 2438 **	11,600	304.8	11,800	10,700
4250 x 2700	4267 x 2743 **	12,000	304.8	13,000	11,800
4250 x 3050	4267 x 3048 **	12,500	304.8	14,100	12,900
4250 x 3350	4267 x 3353 **	13,000	304.8	15,300	14,000
4250 x 3650	4267 x 3658 **	13,400	304.8	16,400	15,100
4250 x 3950	4267 x 3962 **	13,900	304.8	17,600	16,200
4250 x 4250	4267 x 4267 **	14,300	304.8	18,700	17,300

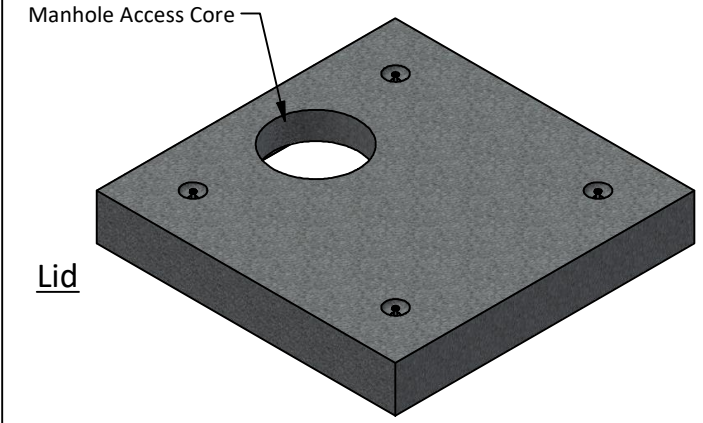

**Lid**

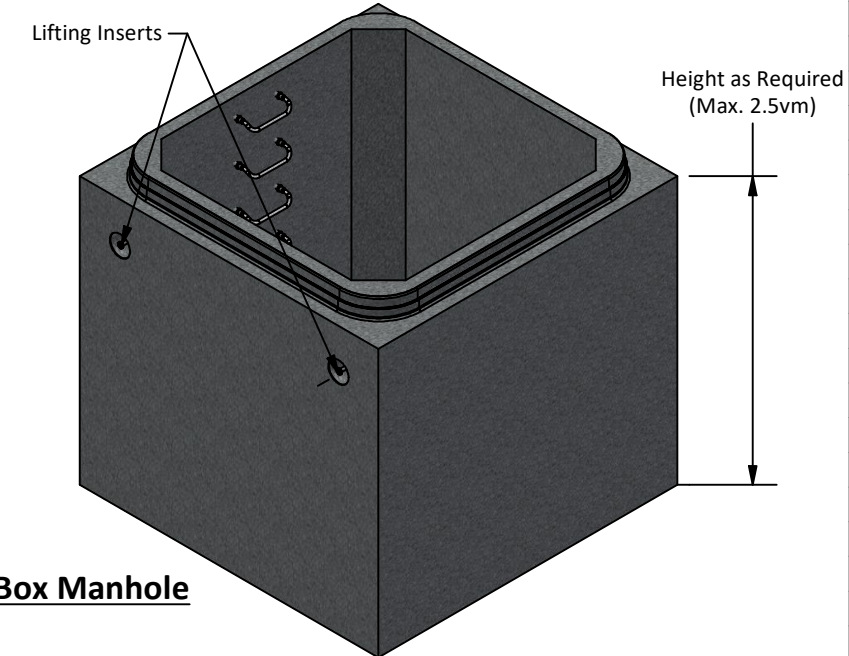

**Box Manhole**

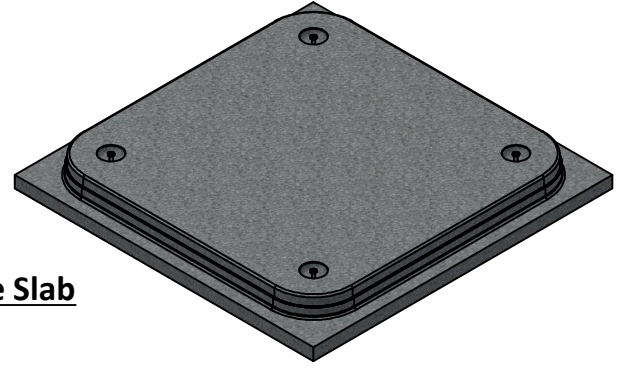

**Base Slab**

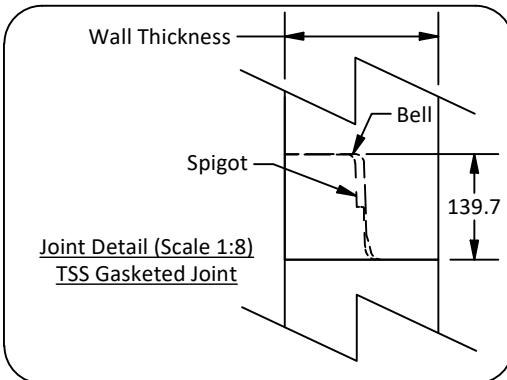
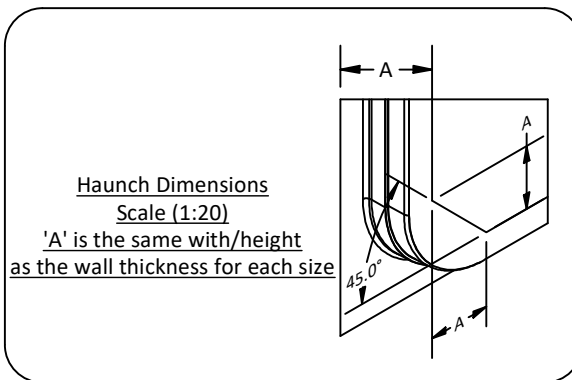

- Note:
- Box culverts are manufactured in accordance with the ASTM C1433/C1433M specification.
  - Box culverts are designed to meet the required design codes and can be manufactured to comply with ASTM C1433, AASHTO, CHBDC, and BC MOT specifications.
  - Units are designed to withstand BCL-625, AASHTO HS20, or E90 live loads. (other loading options available upon request).
  - The standard length is 2.50 m; other lengths are available upon request.
  - Typical shorter lengths start from 1.25, 1.40, 1.55, 1.70, 1.85, 2.00, 2.15, and 2.30 m (in 150 mm increments from 1.25 m).
  - Supplied with a Starcon-style lifting insert as required.  
*Note: Sling angle to vertical must not exceed 15°.*
  - Supplied with TSS gaskets. See the HK TSS gasket information on our website.
  - Box sizes marked with (\*\*) are available in wet-cast only.
  - Dimensions are in millimeters unless otherwise specified.

Amrize Canada Inc. BC Pipe and Precast are certified Q-Cast Plants, an American Concrete Pipe Association Third Party Certification for the manufacture of Pipe, Manhole, Box Culvert and Precast Items.

Quality Assurance of products manufactured by Amrize Canada Inc. BC Pipe and Precast has been verified by the following third party certification programs.

All Dimensions are in Millimeters. Unless otherwise Stated

Projection Method: THIRD ANGLE

www.amrize.com  
CHILLIWACK 1-800 667-9600 / (604) 533-1656  
DUNCAN (250) 478-9581

This drawing is the property of the Amrize Canada Inc. All information contained here in is confidential and may not be used in whole or in part without written permission from the owner.

DESCRIPTION:

**TSS Gasketed Joint  
Box Manhole Details**

DRAWN BY:	SR	DWG NO.:	Box MH-1.0
CHK BY:	MP	JOB NO.:	
DATE:	11-Jul-25	SO NO.:	
SCALE:	1:40	REV.:	
SIZE:	11 x 17	SHEET 1 OF 1	