

PART LIST			
ITEM	QTY	PART NUMBER	MASS
1	1	Bottom Section	6138.4 kg
2	1	Top Section	6853.6 kg
3	1	Spacer Ring 635 x 51	46.3 kg
4	8	5T x 110 mm Lifitng Insert	0.5 kg
5	7	P-14938 Ladder Rung	0.2 kg
6	1	TR 18 Cover	55 kg
7	1	TR 18 Frame	121.9 kg

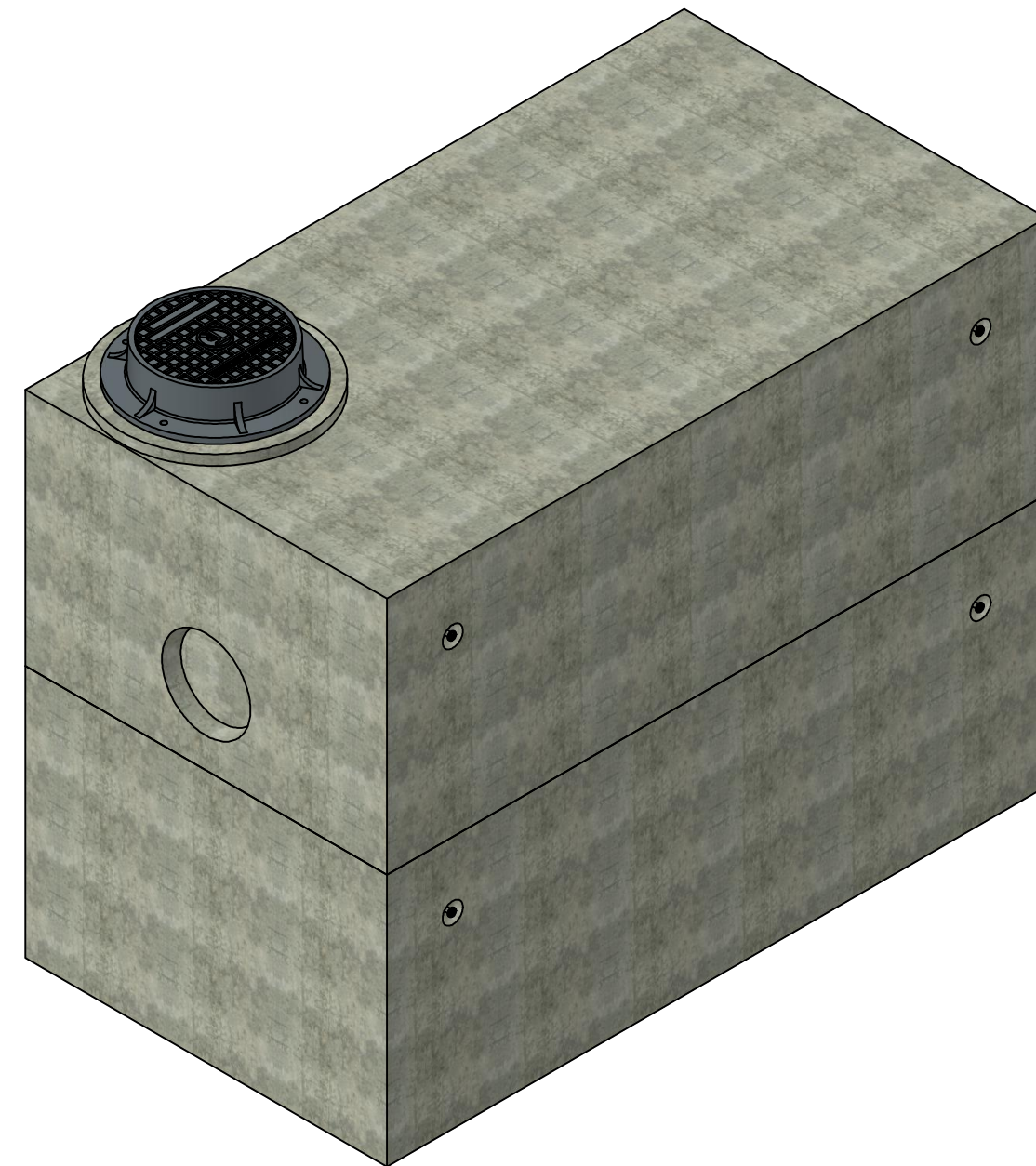

Isometric View

Notes:

- 3152 Reinforced concrete vault is built as shown.
- Unit designed to withstand BCL-625 or AASHTO HS20 live loading.
- Concrete vault designed for the following earth covers:  
*Minimum: 0 m.*  
*Maximum: 2.5 m.*
- Unit supplied with an opening for access as required.
- Unit supplied with knock-out cores for inlet/outlet as required.
- Unit supplied with ladder rungs as required.
- Unit supplied with lifting insert as required. Starcon style min. 5T/ 110mm Lifting Insert to be used.  
*Note: Sling angle to the vertical is no more than 15°.*
- Unit to be installed with Con-Seal 202- Butyl Rubber Sealant for watertight joint.
- Minimum rebar yield strength: 400 MPa. (Steel Grade: CSA G30.18-400 Weldable)
- Minimum concrete strength: 35 MPa.
- Vault interior can be supplied with white paint for improved visibility and cleanliness/cleanliness and the exterior can be damproofed using CS-55 or an approved equivalent.
- All dimensions are in millimeters unless otherwise specified.

Amrize Canada Inc. BC Pipe and Precast are certified Q-Cast Plants, an American Concrete Pipe Association Third Party Certification for the manufacture of Pipe, Manhole, Box Culvert and Precast Items.



All Dimensions are in Millimeters. Unless otherwise Stated



www.amrize.com  
CHILLIWACK 1-800 667-9600 / (604) 533-1656  
DUNCAN (250) 478-9581

DESCRIPTION:

3152 Vault  
Standard Drawing

DRAWN BY: SR	DWG NO.: N/A
CHK BY: MP	JOB NO.: 3152-V
DATE: 18-Jul-25	SO NO.:
SCALE: 1:25	REV.:
SIZE: 11 x 17	SHEET 1 OF 2

Quality Assurance of products manufactured by Amrize Canada Inc. BC Pipe and Precast has been verified by the following third party certification programs.



Projection Method:  
THIRD ANGLE



This drawing is the property of the Amrize Canada Inc. All information contained here in is confidential and may not be used in whole or in part without written permission from the owner.

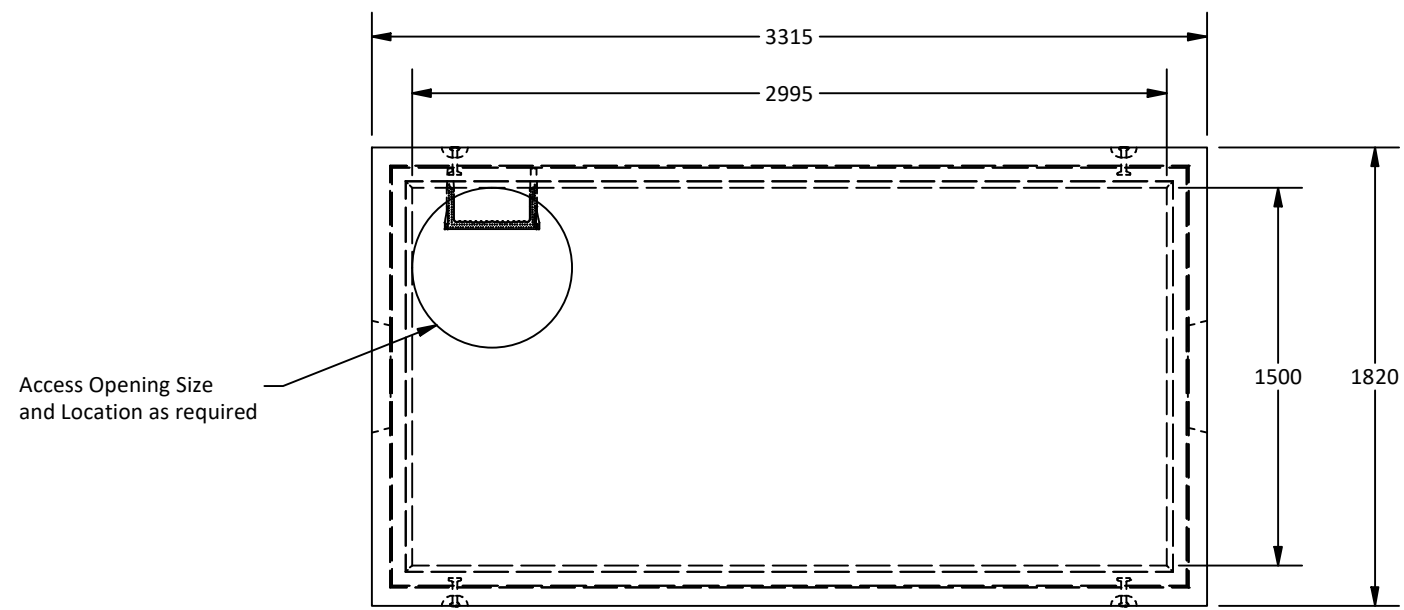

Plan View

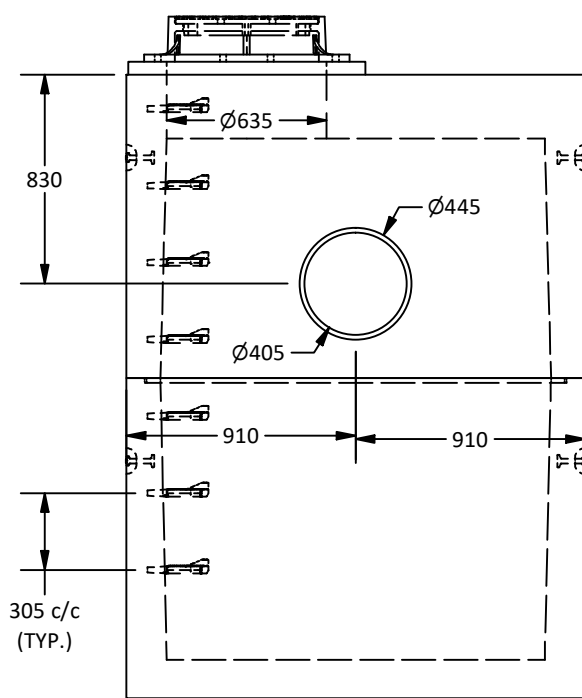

West View

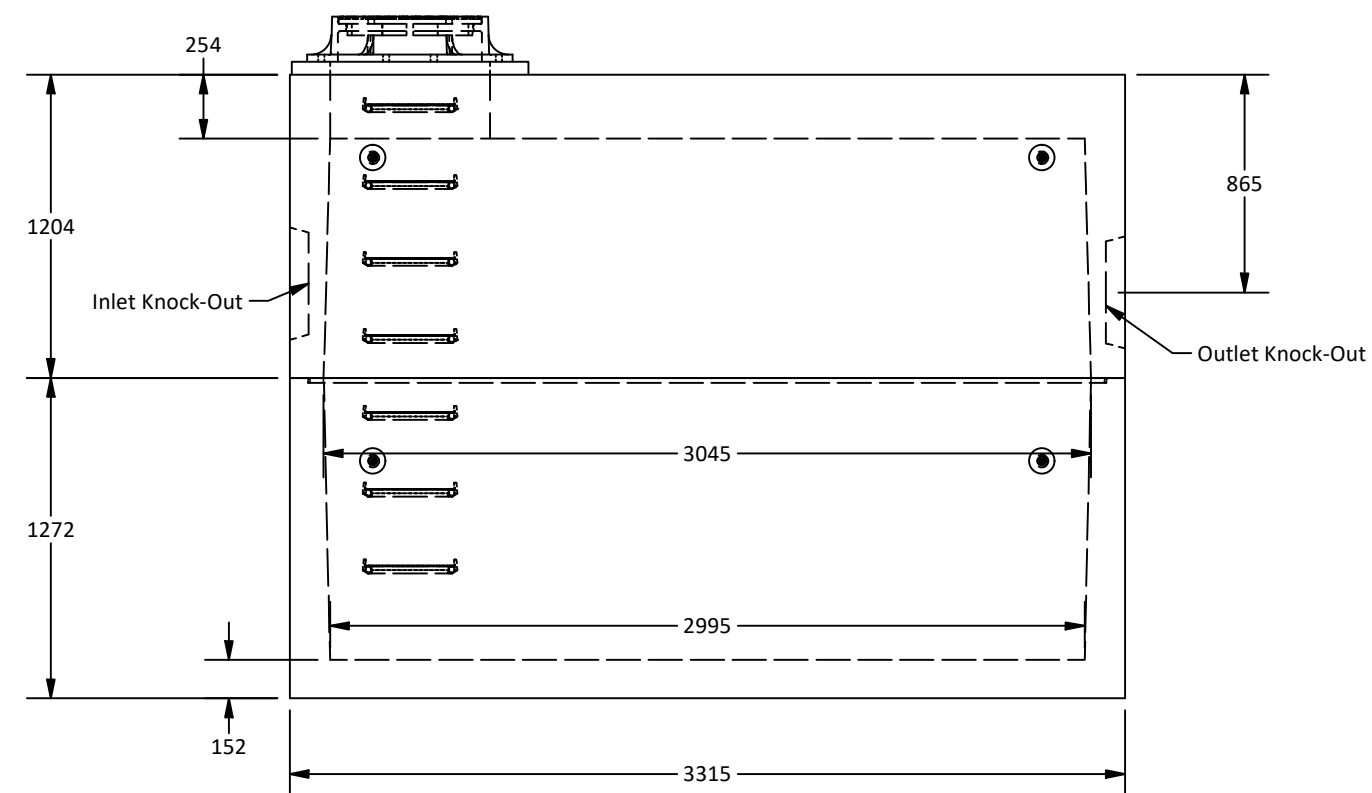

Elevation View

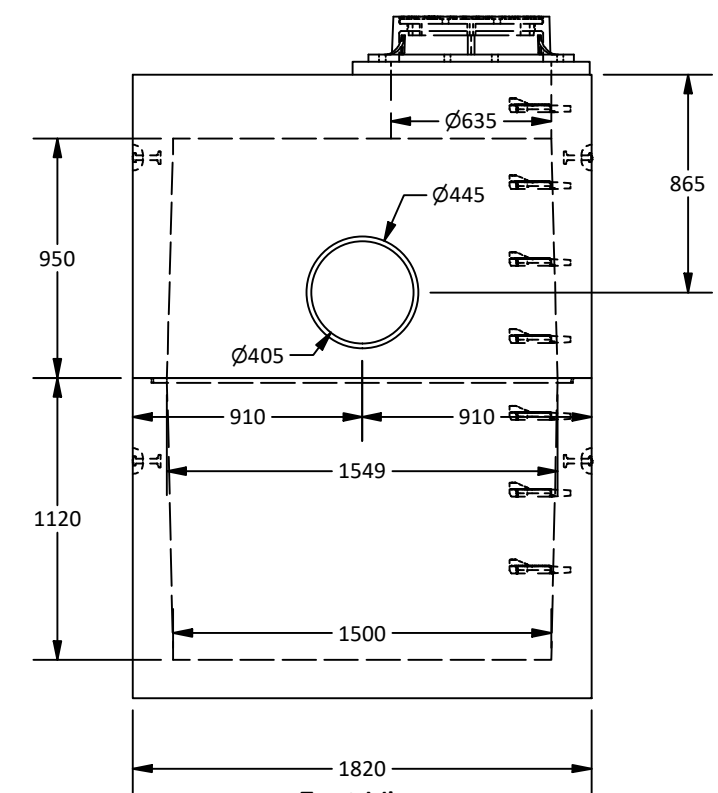

East View

Amrize Canada Inc. BC Pipe and Precast are certified Q-Cast Plants, an American Concrete Pipe Association Third Party Certification for the manufacture of Pipe, Manhole, Box Culvert and Precast Items.



All Dimensions are in Millimeters. Unless otherwise Stated



www.amrize.com  
CHILLIWACK 1-800 667-9600 / (604) 533-1656  
DUNCAN (250) 478-9581

DESCRIPTION:  
  
**3152 Vault  
Standard Drawing**

DRAWN BY:	SR	DWG NO.:	N/A
CHK BY:	MP	JOB NO.:	3152-V
DATE:	18-Jul-25	SO NO.:	
SCALE:	1:30	REV.:	
SIZE:	11 x 17		

	SHEET 2 OF 2
--	--------------

Quality Assurance of products manufactured by Amrize Canada Inc. BC Pipe and Precast has been verified by the following third party certification programs.



Projection Method:  
THIRD ANGLE

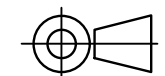

This drawing is the property of the Amrize Canada Inc. All information contained here in is confidential and may not be used in whole or in part without written permission from the owner.