

PART LIST			
ITEM	QTY	PART NUMBER	MASS
1	4	Unistrut P3300	0.65 kg
2	1	1.2 x 1.2 Vault	594.73 kg
3	4	2.5T x 68mm Lifitng Insert	0.09 kg

Notes:

- 1.2 x 1.2 vault is built as shown.
- Unit designed to withstand 2. BCL-625/ AASHTO HS20 live load.
- Concrete vault designed for following earth cover:
Minimum: 0m
Maximum: 2.5m.
- Unit supplied with 5 x $\varnothing 102$ mm cores for duct terminator as shown.
- Unit supplied with 4 x Unistrut P3370 as shown.
- Unit supplied with 2 x 250mm x 250mm sump as shown.
- Unit to be installed with Con-Seal 202- Butyl Rubber Sealant for watertight joint.
- Minimum rebar yield strength: 400 MPa. (Steel Grade: CSA G30.18-400 Weldable)
- Minimum concrete strength: 35 MPa.
- Unit supplied w/ lifting insert as required. Starcon style min. 2.5T/ 68mm lifting inserts to be used.
Note: Sling angle to the vertical no more than 15°.
- Unit supplied with ferrule inserts if required.
- Vault interior can be supplied with white paint for improved visibility/cleanliness and damproofed exterior using CS-55 or approved equivalent.
- All dimensions are in millimeters unless otherwise specified.

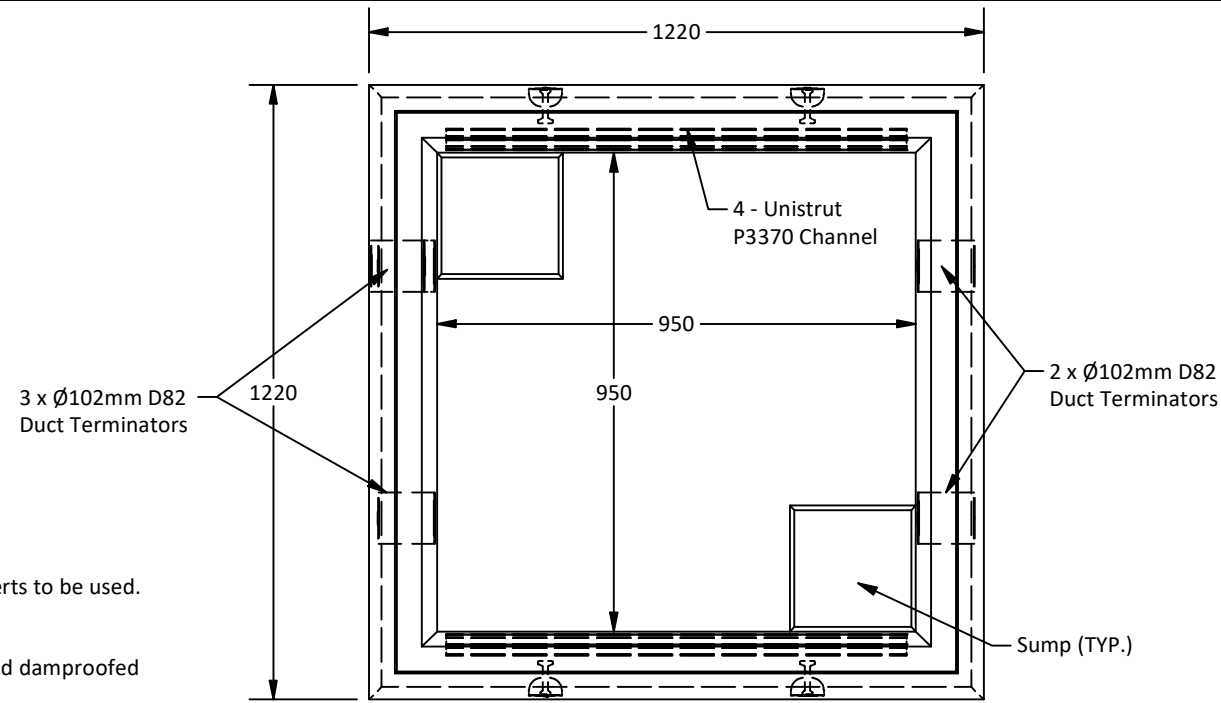

Plan View

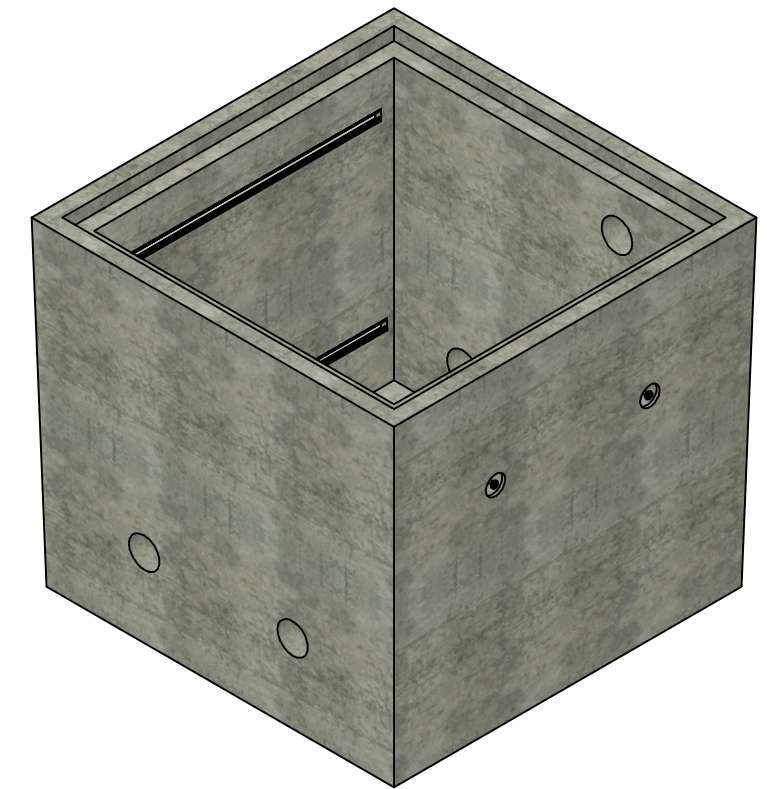

Isometric View

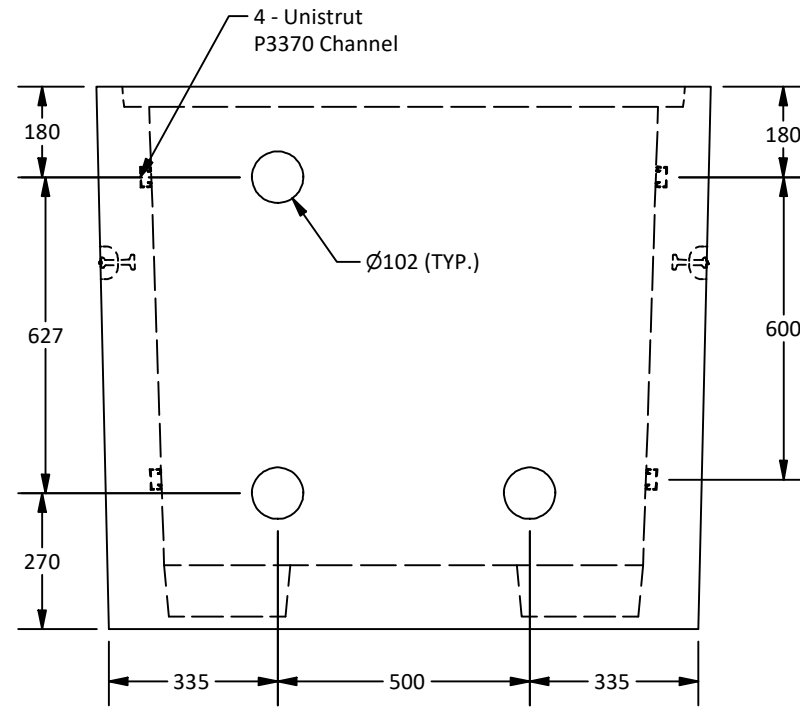

West View

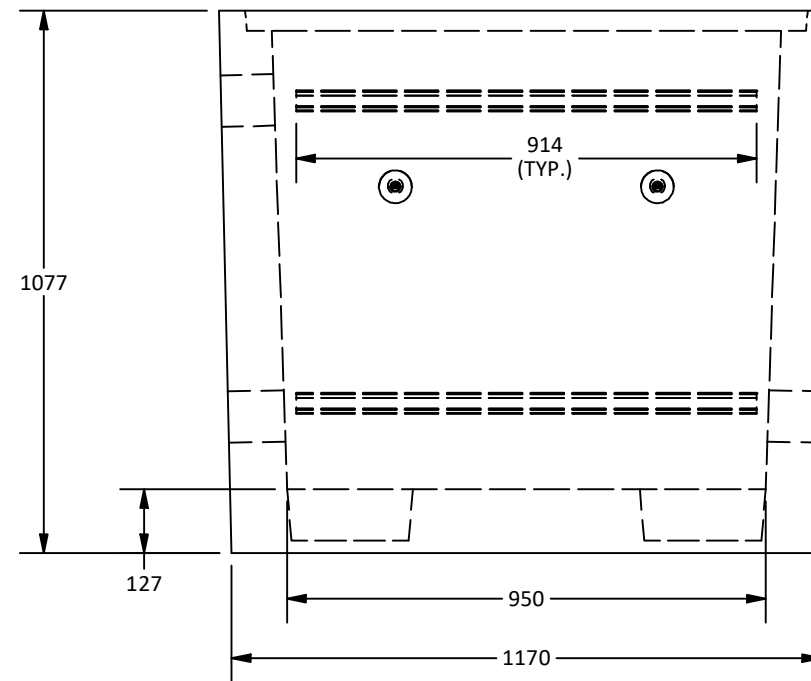

Elevation View

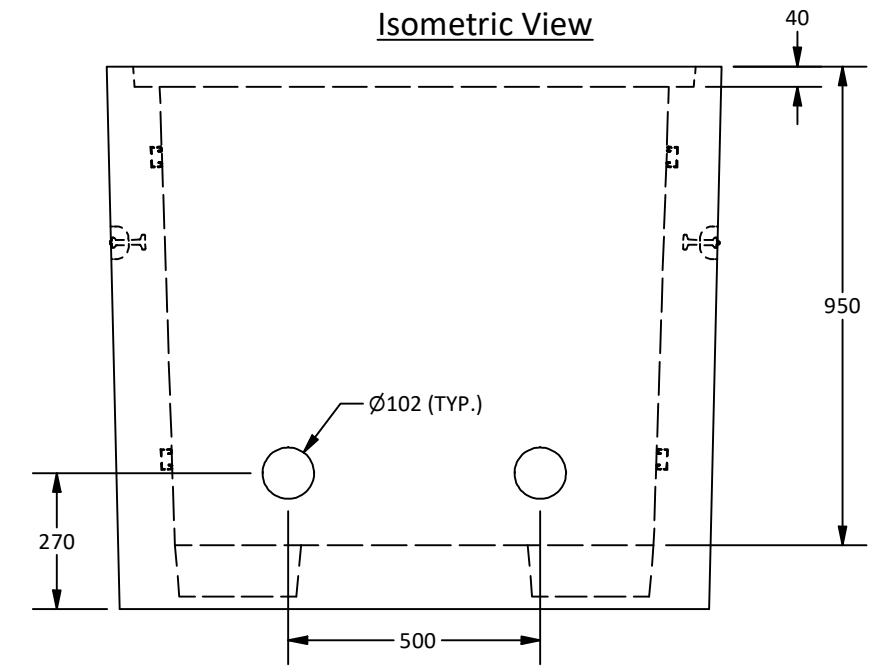

East View

Amrize Canada Inc. BC Pipe and Precast are certified Q-Cast Plants, an American Concrete Pipe Association Third Party Certification for the manufacture of Pipe, Manhole, Box Culvert and Precast Items.



All Dimensions are in Millimeters. Unless otherwise Stated



www.amrize.com
CHILLIWACK 1-800 667-9600 / (604) 533-1656
DUNCAN (250) 478-9581

DESCRIPTION:

1.2 x 1.2 Cable Communication Vault
Standard Drawing

DRAWN BY: SR

DWG NO.: 1.2 x 1.2 -CCV

CHK BY: MP

JOB NO.:

DATE: 01-Oct-25

SO NO.:

SCALE: 1:15

REV.:

SIZE: 11 x 17

SHEET 1 OF 1

Quality Assurance of products manufactured by Amrize Canada Inc. BC Pipe and Precast has been verified by the following third party certification programs.



Projection Method: THIRD ANGLE



This drawing is the property of the Amrize Canada Inc. All information contained here in is confidential and may not be used in whole or in part without written permission from the owner.